

HYDRA-PAK Model 1500

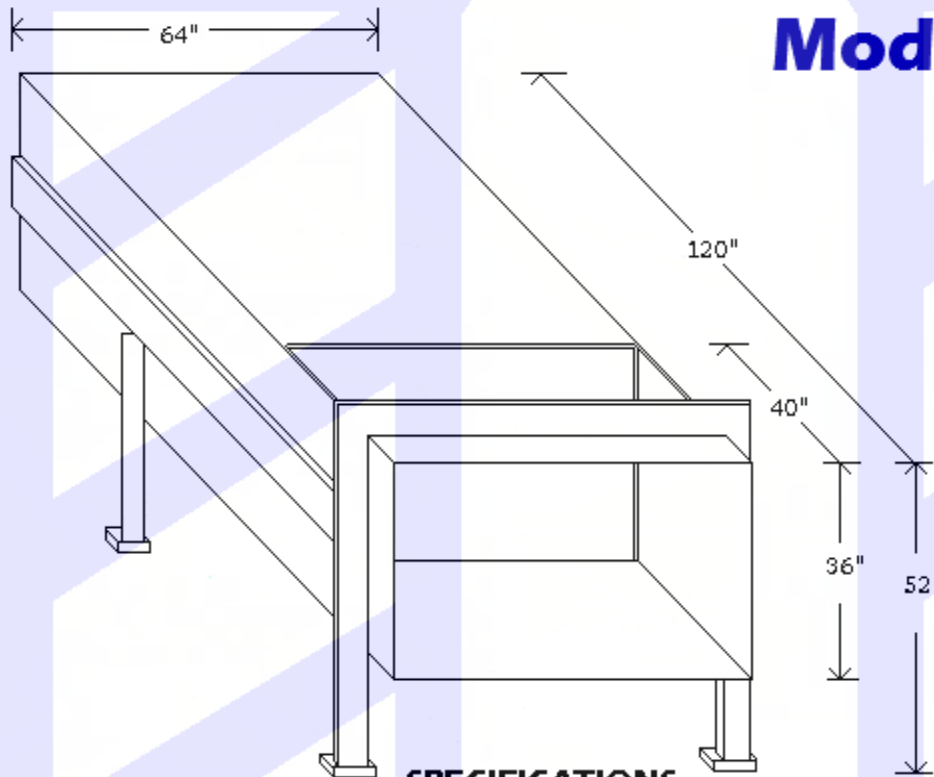

SPECIFICATIONS

MECHANICAL

Compactor Weight:	Gross 5768 lbs.
Charging Chamber Cap:	1.5 Cu. Yds.
Chamber Opening:	40" x 60" x 36"
Ram Face Diameter:	60" x 30"
Ram Penetration:	10 inches

CONSTRUCTION

Sides 1/4 inch, floor 3/8 inch
Hot Rolled Steel
Reinforced 3" x 6" x 1/4"

ELECTRICAL

Control System:	110 volts, 60 cycles
Motor:	10HP 3 Phase 60 Cycles, Power Range - 208-416-230-460-575 volts
Control Panel:	Fully wired with fuse protection, on-off switch, start-stop button, on indicator light, full indicator light.

HYDRAULICS

Compaction Force:	56,000 lbs. maximum
Compaction Force:	51,000 lbs. normal
Max. Displacement:	185 Cu. Yd. per Hour
Cycle Time:	45 seconds
Pressure:	
Normal:	1,800 psi
Maximum:	2,000 psi
Pump Capacity:	15 G.P.M.
Cylinder:	One 6" bore, 54" stroke D.A.
Ram Pressure:	30 psi
Oil Capacity:	30 gallons

**Specifications are approximate and subject to change without notification.
Dimensions will vary with options in Compactor and Container size.**

HYDRA-PAK SYSTEMS LIMITED
 2501 Beryl Road
 Oakville, Ontario, L6J 7X3
 Tel: 905-844-7844
 email: look@hydrapaksystems.com