



# CANTILEVER

# SLIDING GATES

# HARDWARE

# HI-MOTIONS' EXPERIENCE IN THE WORLD OF ACCESSORIES HAS A FUNDAMENTAL MISSION OF CREATING STRONG PARTNERSHIPS WITH PROFESSIONALS

## TECHNICAL SYNERGY AND INNOVATION.

---

Hi-Motions came out of technological synergy between the worlds of automation and gate accessories. Innovation, research but also deep knowledge of the market and its needs have become strategic elements for the company. This lets it today offer a full range, which includes accessories for swing, sliding and free-standing gates, industrial doors as well as integrated solutions that open the way to new contexts and new needs. «Opening solutions» summarises the company's mission: offering solutions for all types of closures, guaranteeing reliability but above all flexibility.

RIENCE

GATE

BECOME

MEANS

SHIPS

ALS.



**06**

**ON-LINE CONFIGURATOR**  
configurator.himotionsusa.com

**07**

**CANTILEVER SLIDING GATES**  
Installation and Measurement

**10**

**CANTILEVER SLIDING GATES**  
Pad - Mount

**12**

**CANTILEVER SLIDING GATES**  
Post - Mount

**14**

**CANTILEVER SLIDING GATES**  
Medium Series

**16**

**CANTILEVER SLIDING GATES**  
Extra Medium Series

**18**

**CANTILEVER SLIDING GATES**  
Large Series

**20**

**CANTILEVER SLIDING GATES**  
Extra Large Series

**22**

**TOP CANTILEVER TRACK**  
Medium Series

**26**

**CANTILEVER SLIDING GATES**  
Accessories

**29**

**SLIDING GATES**  
Wheels

**34**

**INDUSTRIAL DOORS**  
Overhead Tracks

# ON-LINE CONFIGURATOR

For HI-MOTIONS, the “service” is first of all “communication”. The customer is for us the partner, but above all the main spokesperson of the brand in the territory. For this reason the company supports its customers both in the choice and in the knowledge of its products. The configurator grows out of these important premises: it is a professional instrument, available online and easy to use thanks to its step-by-step approach. With the insertion of data and parameters, this tool configures the cantilever gate and indicates the related accessories necessary to install it.

HI-MOTIONS offers its customers a consulting service for the design and creation of special systems, or for providing useful information, advice and suggestions. Contact the company to discover all the potential solutions and applications for HI MOTIONS products, or consult on-line the configurator designed to guide customers in selecting the most suitable product and solution for their requirements!

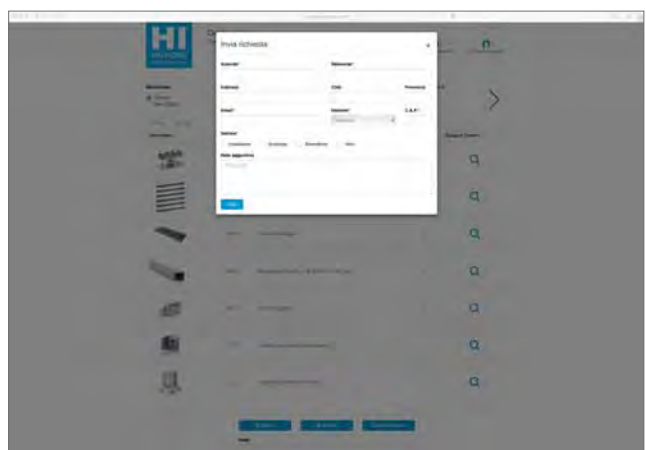
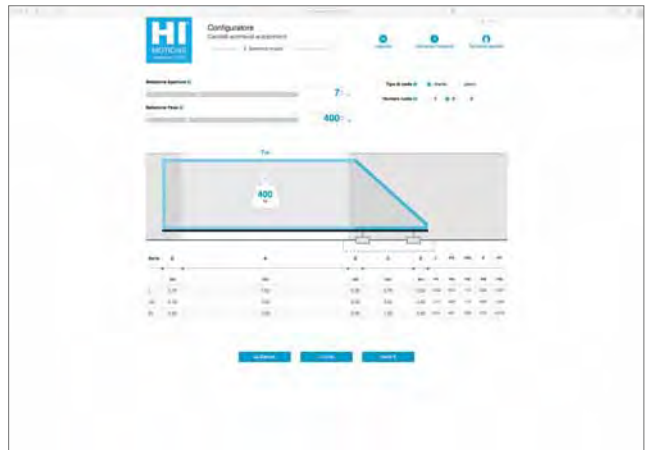

## CANTILEVER SLIDING GATES INSTALLATION AND MEASUREMENT\*

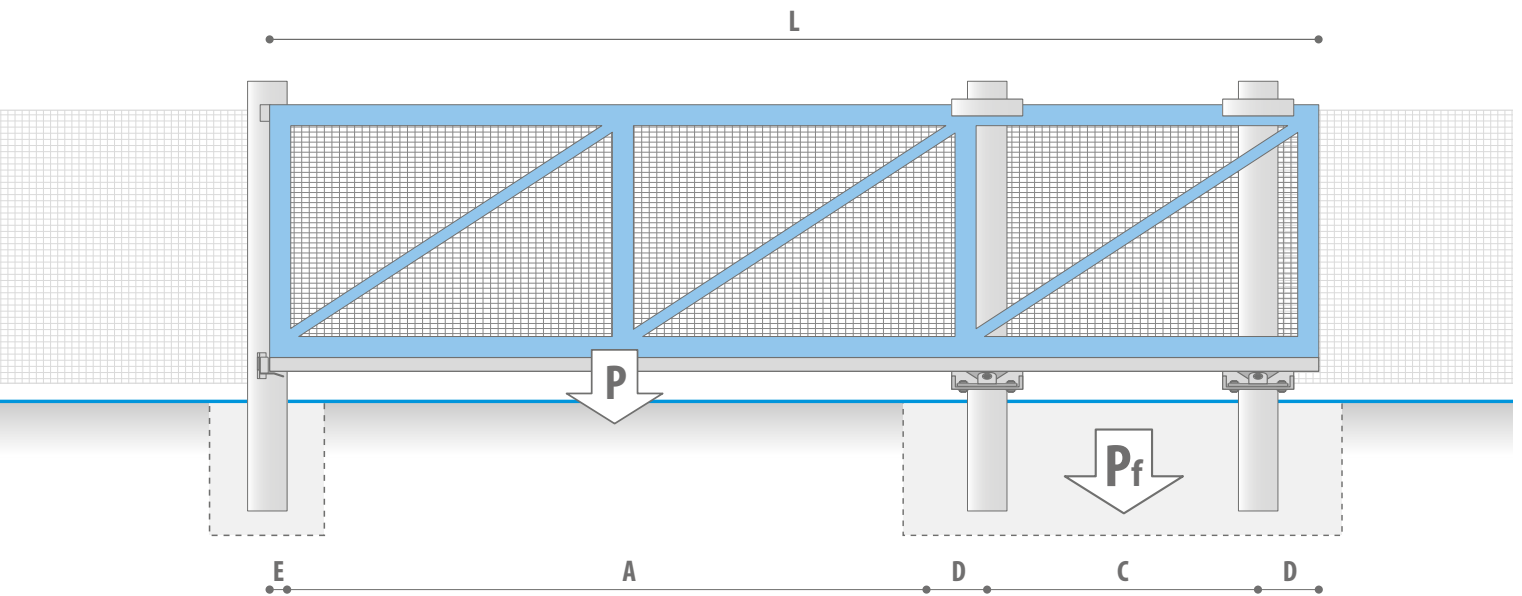

- A** (ft) clear opening
- C** (lbs) distance between the support rollers centre
- D** (ft) minimum distance from support roller centre to track end for support roller housing
- E** (ft) minimum space for support wheel positioning
- L** (ft) overall gate length ( $L=A+C+2xD+E$ )
- PS** (lbs) gate weight without track
- PM** (lbs) track's weight
- P** (lbs) total weight: ( $P=PS+PM$ )
- Pf** (lbs) minimum weight of the foundation to compensate stress on both carriages, produced by cantilevered part

\* Weight and dimensions are indicative only. May vary according to the installation site. Please verify with civil engineer. Always refer to local applicable safety standards in terms of the gate construction and its installation.

**CANTILEVER**  
**GATE INSTALLATION**  
**PAD-MOUNT**







**CANTILEVER**  
**GATE INSTALLATION**  
**POST-MOUNT**

## CANTILEVER SLIDING GATES PAD-MOUNT



Guide Plates

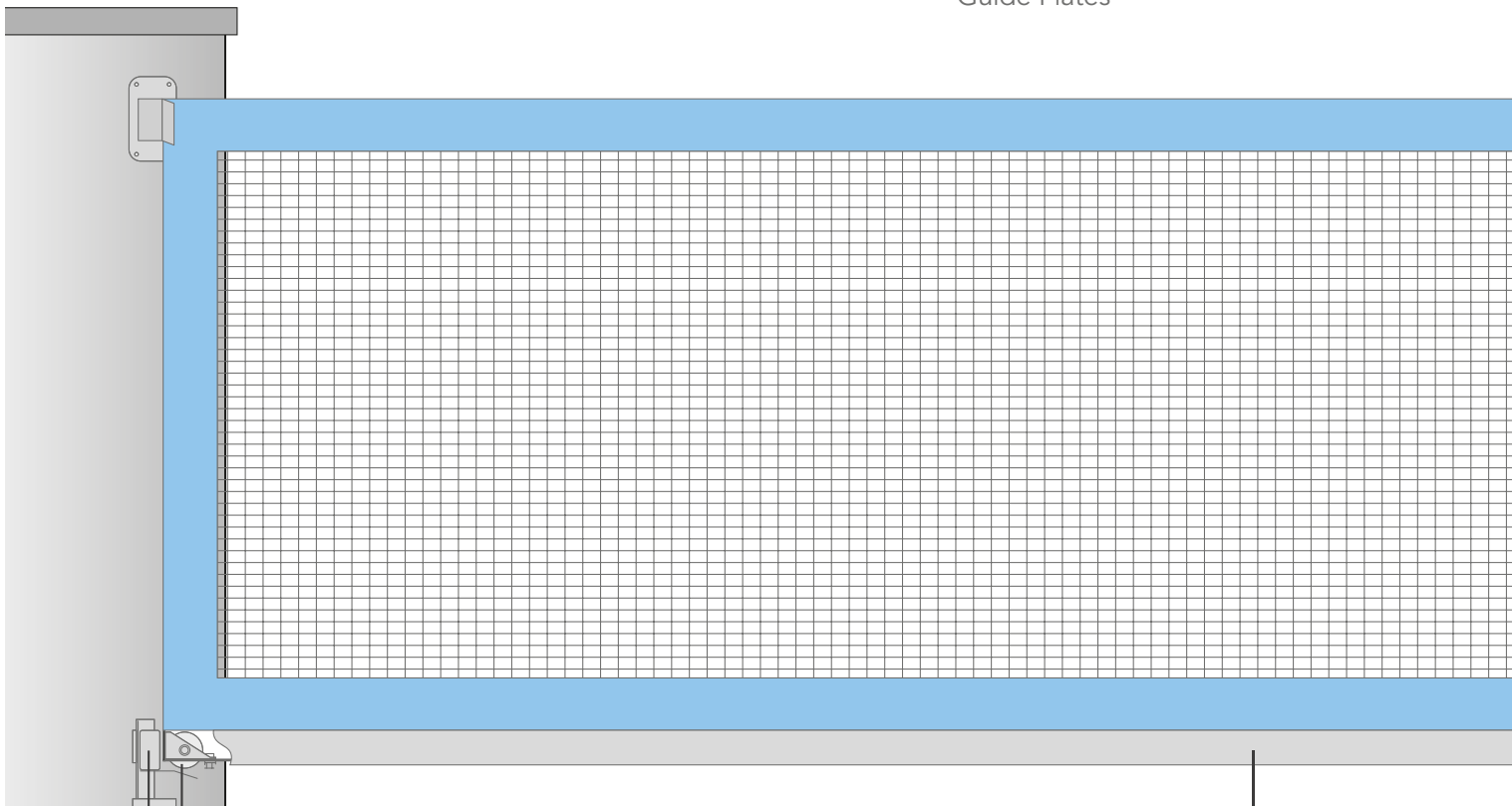

Gate Catch



Guide Roller



Track

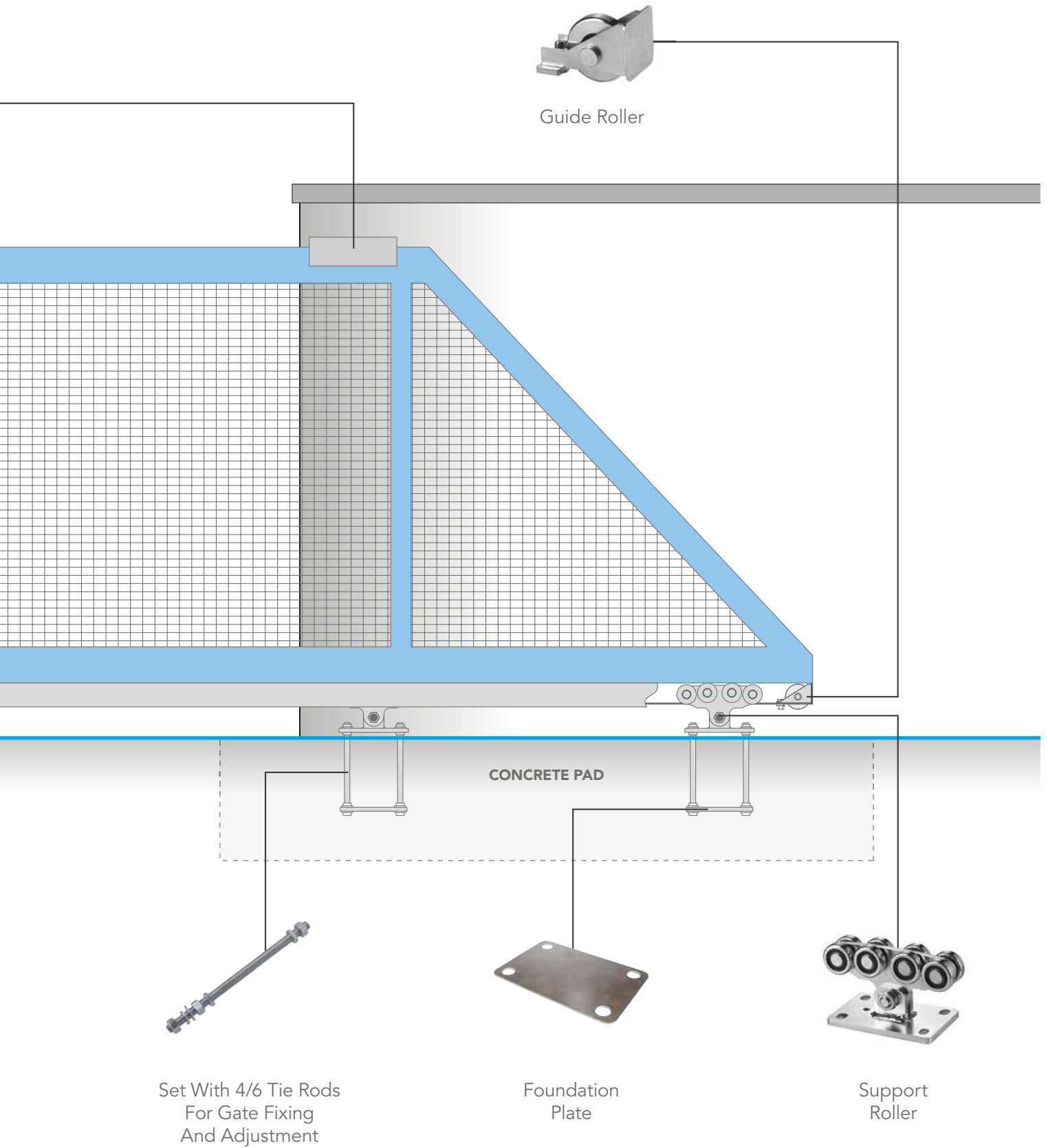

# CANTILEVER SLIDING GATES **POST-MOUNT**



Guide Plates

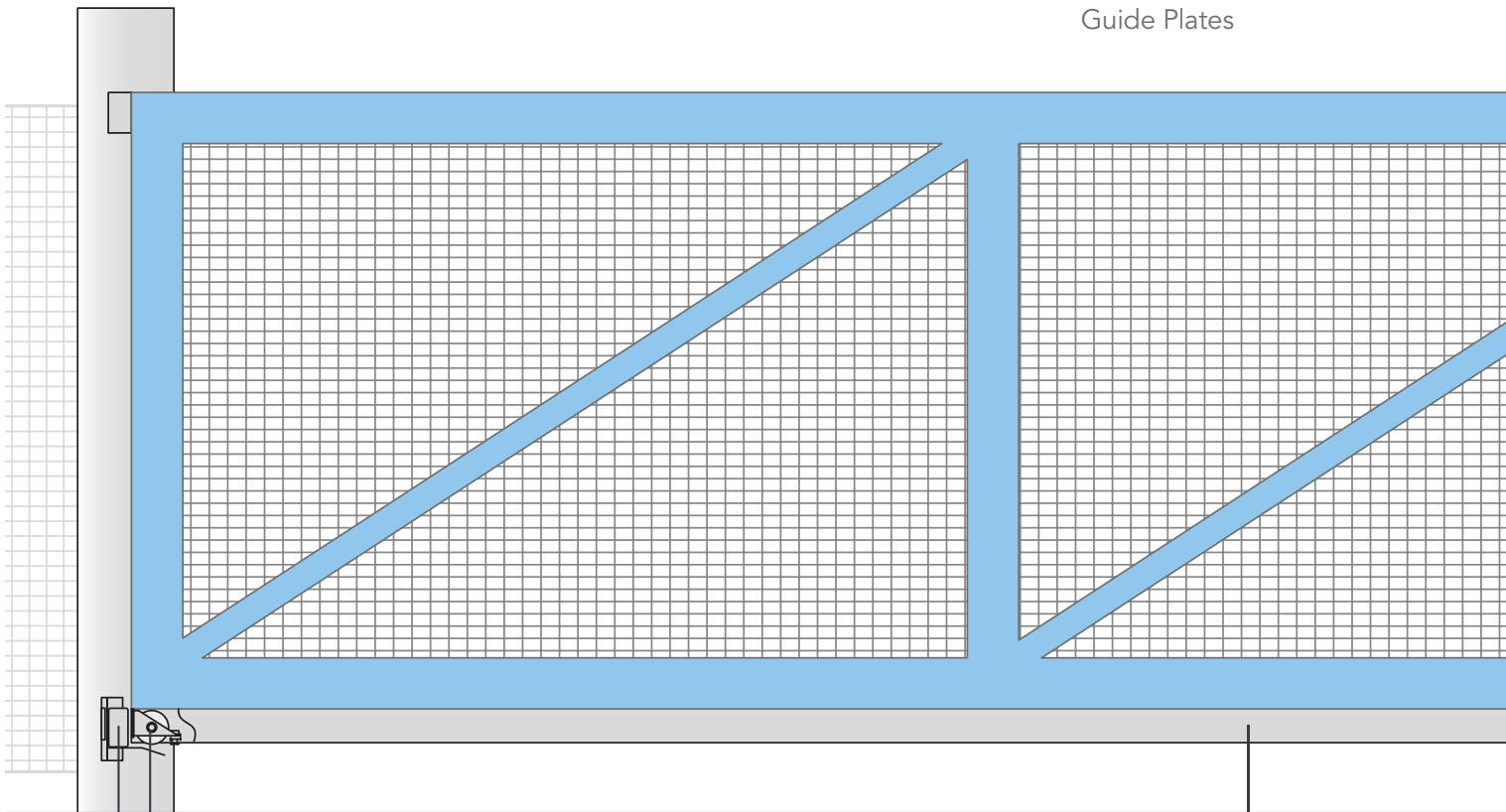

Gate Catch



Guide Roller



Track

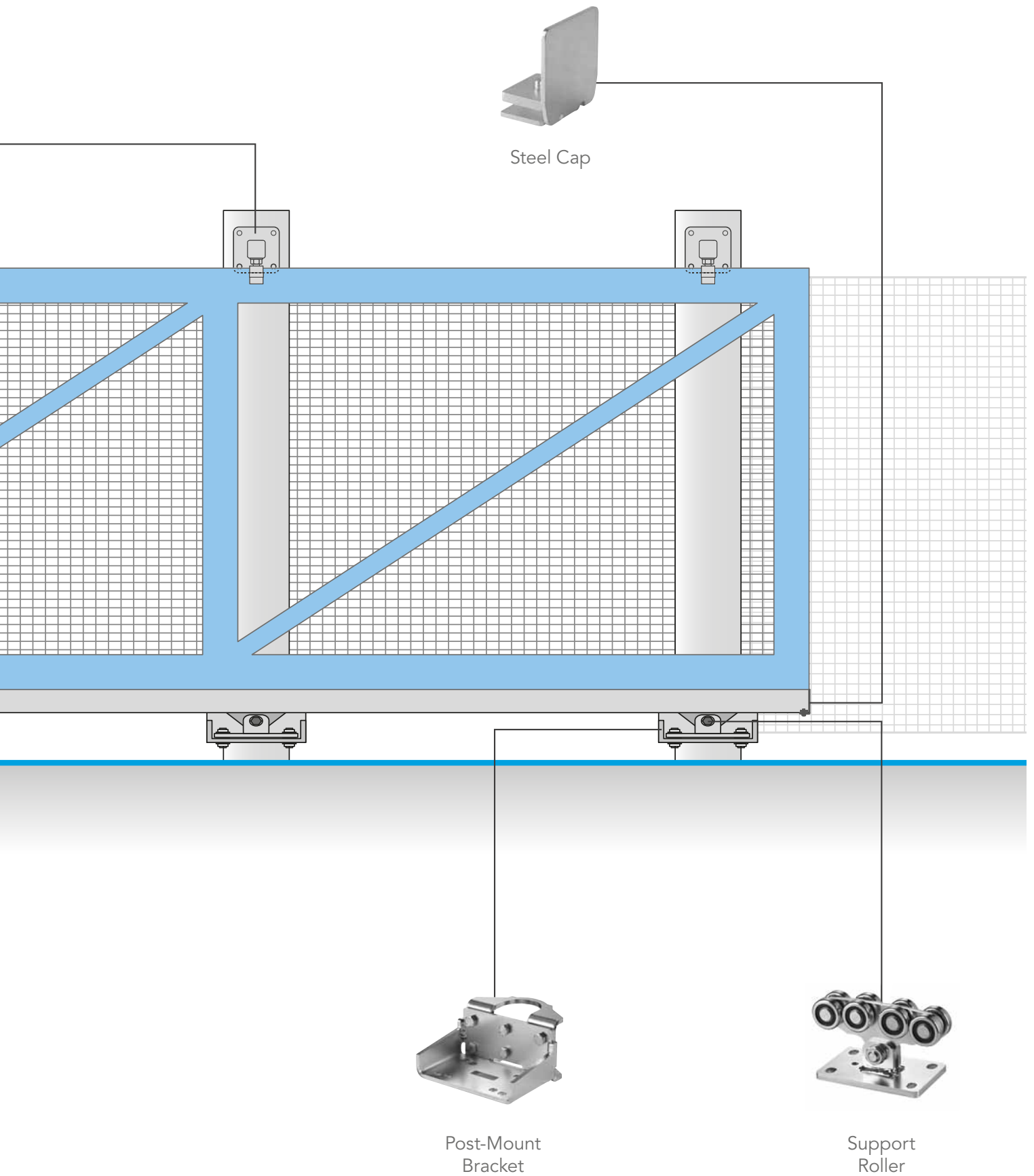

# CANTILEVER SLIDING GATES MEDIUM SERIES

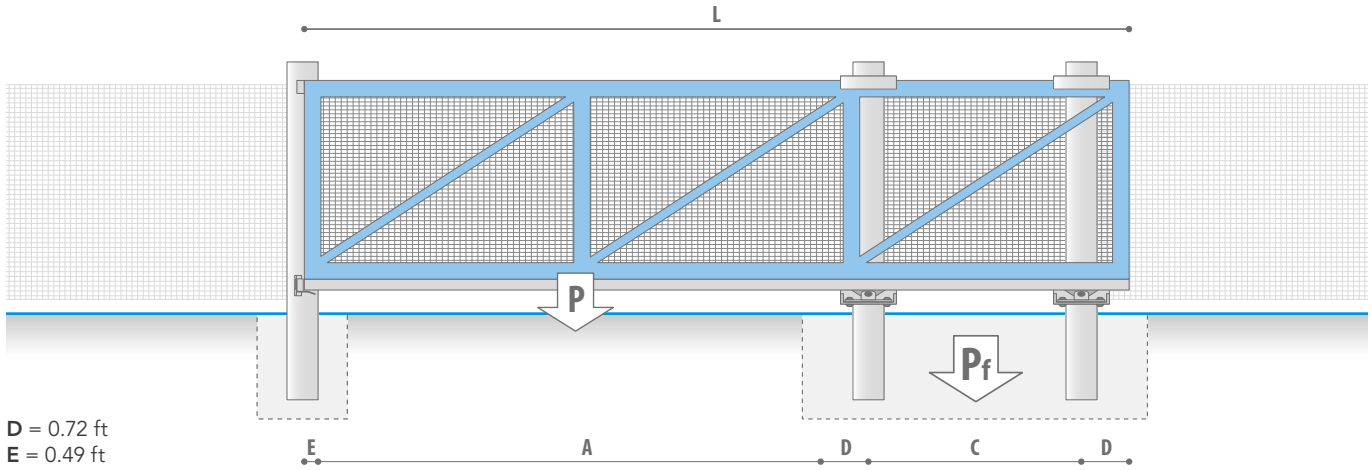

M	GATE WEIGHT ONLY																			
	300 lbs					400 lbs					500 lbs					600 lbs				
A	C	L	PM	P	PF	C	L	PM	P	PF	C	L	PM	P	PF	C	L	PM	P	PF
12 ft	1.82	15.75	56	449	2793	2.55	16.48	58	608	2572	3.43	17.36	61	784	2351	4.48	18.41	65	985	2130
14 ft	2.15	18.08	64	451	2778	3	18.93	67	608	2557	4.01	19.94	70	783	2336	5.24	21.17	75	982	2115
16 ft	2.49	20.42	72	455	2762	3.46	21.39	76	610	2541	4.62	22.55	80	784	2320	6.03	23.96	85	983	2099
18 ft	2.84	22.77	80	460	2747	3.94	23.87	84	615	2526	5.25	25.18	89	788	2305	6.84	26.77	95	987	2084
20 ft	3.21	25.14	89	466	2731	4.44	26.37	93	621	2510	5.91	27.84	98	794	2289	7.68	29.61	105	993	2068
22 ft	3.6	27.53	97	473	2715	4.96	28.89	102	627	2494	6.58	30.51	108	801	2273	8.55	32.48	115	1001	2052
24 ft	4.01	29.94	106	480	2700	5.5	31.43	111	635	2479	7.28	33.21	117	809	2258	9.45	35.38	125	1009	2037

## M SUPPORT ROLLER

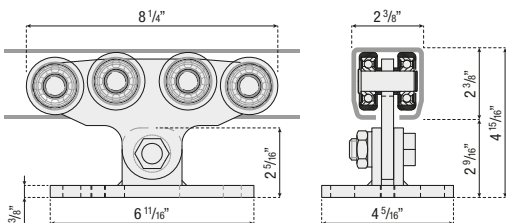
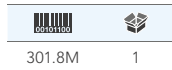

## M TRACK

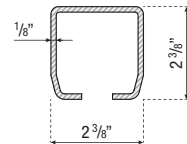

Barcode	L (ft)	TRACK WEIGHT	FINISHING
323.6	20	3.53 lb/ft	galvanized

## M FOUNDATION PLATE

303.8M	2

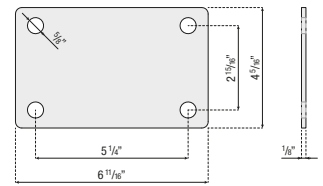

## M POST-MOUNT BRACKET



304.M102Q

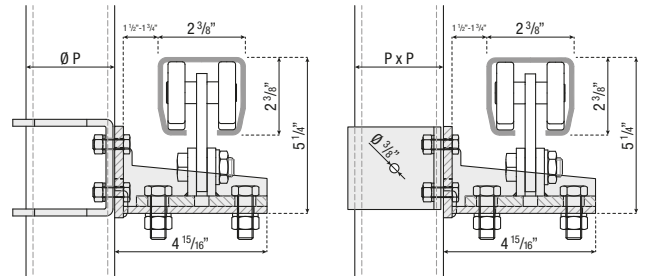

	POST DIMENSION	
304.M73	Ø 3"	2
304.M102	Ø 4"	2
304.M102Q	□ 4" x 4"	2

## M GUIDE ROLLER

307.M	2

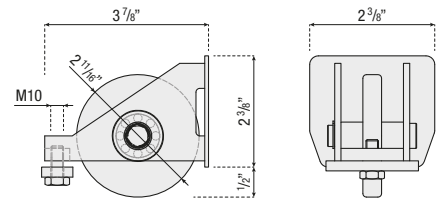

## M STEEL CAP

309.M	10

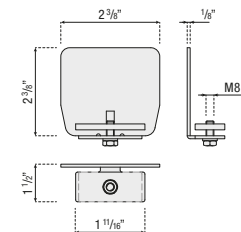

## M GATE CATCH

310.M	2

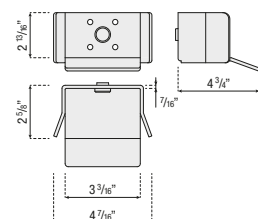

# CANTILEVER SLIDING GATES EXTRA MEDIUM SERIES

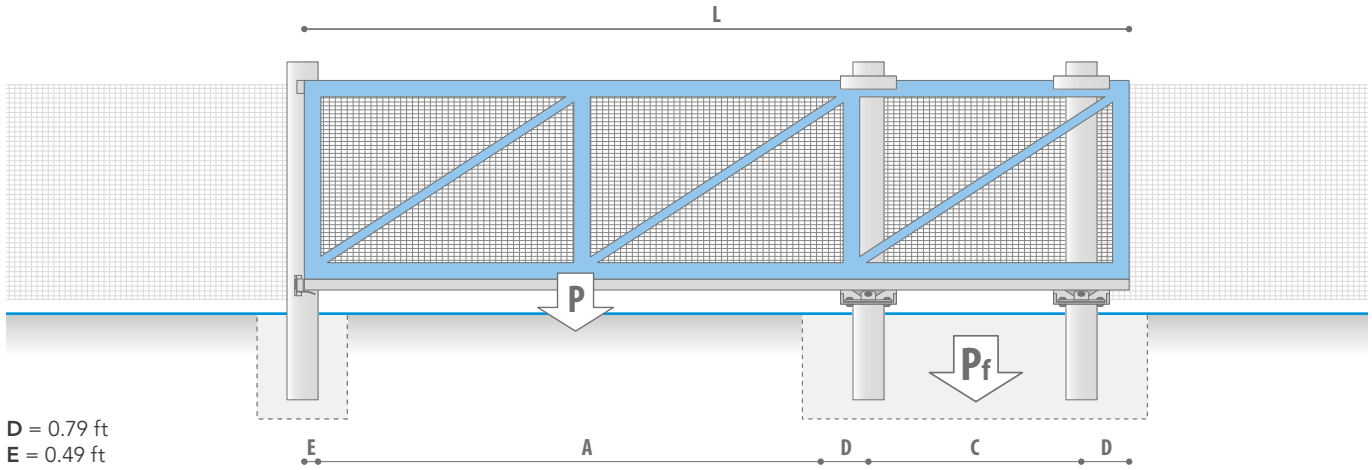

## XM

### GATE WEIGHT ONLY

A	300 lbs					400 lbs					500 lbs					600 lbs				
	C	L	PM	P	PF	C	L	PM	P	PF	C	L	PM	P	PF	C	L	PM	P	PF
14 ft	1.76	17.83	72	454	3492	2.4	18.47	74	602	3271	3.14	19.21	77	764	3050	3.99	20.06	81	941	2829
16 ft	2.04	20.11	81	458	3474	2.77	20.84	84	605	3253	3.62	21.69	87	765	3032	4.59	22.66	91	941	2811
18 ft	2.33	22.4	90	464	3457	3.16	23.23	94	610	3236	4.11	24.18	97	769	3015	5.21	25.28	102	944	2794
20 ft	2.64	24.71	100	470	3439	3.56	25.63	103	616	3218	4.62	26.69	108	775	2997	5.85	27.92	113	950	2776
22 ft	2.96	27.03	109	478	3421	3.98	28.05	113	623	3200	5.15	29.22	118	782	2979	6.51	30.58	123	957	2758
24 ft	3.29	29.36	118	485	3403	4.41	30.48	123	631	3182	5.7	31.77	128	790	2961	7.19	33.26	134	965	2740
30 ft	4.38	36.45	147	511	3350	5.81	37.88	153	658	3129	7.45	39.52	159	818	2908	9.36	41.43	167	996	2687

## XM SUPPORT ROLLER

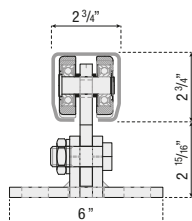
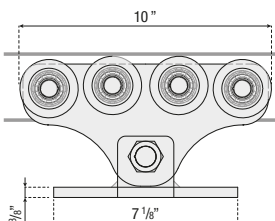
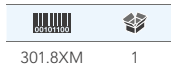

## XM TRACK

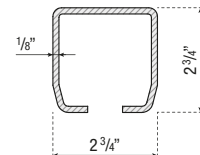

Barcode	L (ft)	TRACK WEIGHT	FINISHING
338.6	20	4.03 lb/ft	galvanized



## XM FOUNDATION PLATE

303.8XM	2

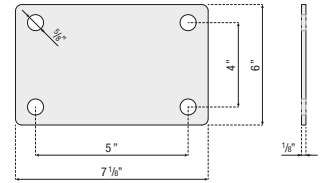

## XM POST-MOUNT BRACKET



304.M102Q

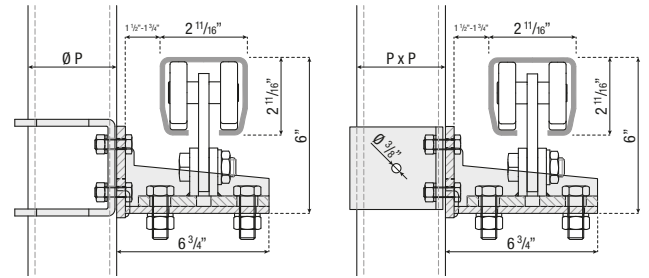

	POST DIMENSION	
304.XM73	Ø 3"	2
304.XM102	Ø 4"	2
304.XM102Q	□ 4" x 4"	2

## XM GUIDE ROLLER

307.XM	2

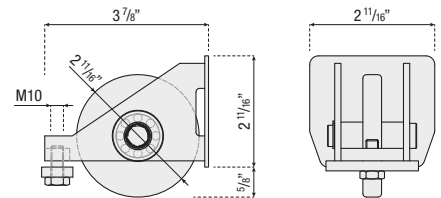

## XM STEEL CAP

309.XM	10

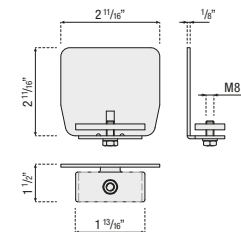

## XM GATE CATCH

310.XM	2

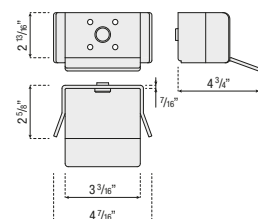

# CANTILEVER SLIDING GATES LARGE SERIES

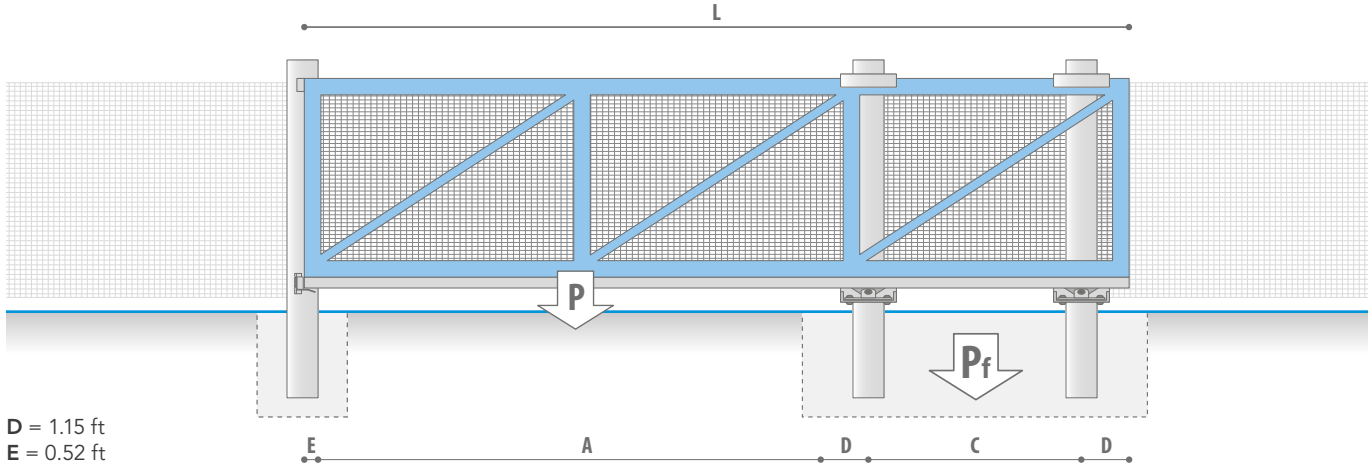

L	GATE WEIGHT ONLY																			
	400 lbs					600 lbs					800 lbs					1000 lbs				
A	C	L	PM	P	PF	C	L	PM	P	PF	C	L	PM	P	PF	C	L	PM	P	PF
15 ft	2.11	19.93	157	688	4697	3.22	21.04	165	1007	4255	4.6	22.42	176	1372	3813	6.34	24.16	190	1800	3371
20 ft	2.98	25.8	203	719	4611	4.48	27.3	215	1033	4169	6.33	29.15	229	1395	3727	8.68	31.5	248	1823	3285
25 ft	3.98	31.8	250	759	4524	5.89	33.71	265	1074	4082	8.26	36.08	284	1438	3640	11.29	39.11	307	1872	3198
30 ft	5.11	37.93	298	804	4437	7.47	40.29	317	1122	3995	10.41	43.23	340	1492	3553	14.18	47	369	1936	3111
40 ft	7.83	50.65	398	905	4263	11.19	54.01	424	1235	3821	15.41	58.23	458	1622	3379	20.92	63.74	501	2094	2937
50 ft	11.21	64.03	503	1015	4089	15.73	68.55	539	1361	3647	21.51	74.33	584	1733	3205	29.13	81.95	644	2283	2763

## L SUPPORT ROLLER

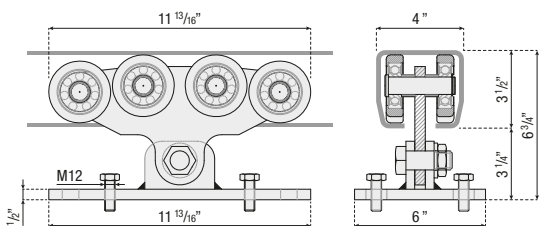

## L TRACK

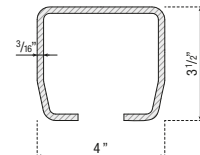

Available upon request on 36 ft lengths

	L (ft)	TRACK WEIGHT	FINISHING
	20	7.86 lb/ft	galvanized

## L FOUNDATION PLATE

303.8L	2

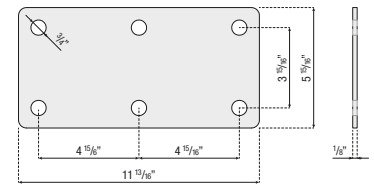

## L POST-MOUNT BRACKET

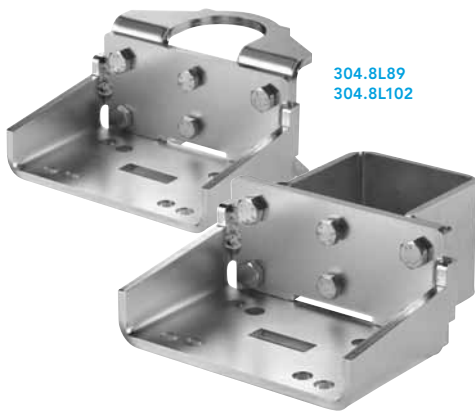

304.8L89  
304.8L102

304.8L89Q  
304.8L102Q

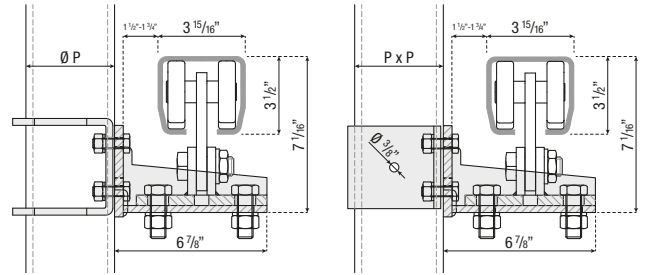

	POST DIMENSION	
304.8L89	Ø 3 1/2"	2
304.8L102	Ø 4"	2
304.8L89Q	□ 3 1/2" x 3 1/2"	2
304.8L102Q	□ 4" x 4"	2

## L GUIDE ROLLER

307.L	2

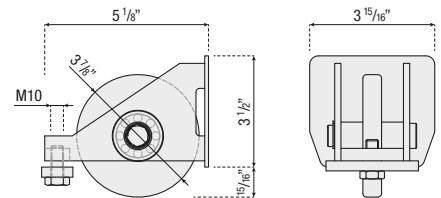

## L STEEL CAP

309.L	4

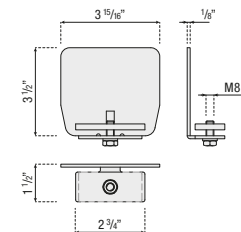

## L GATE CATCH

310.L	2

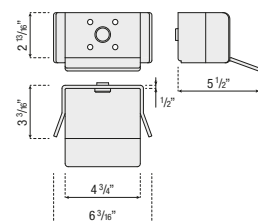

# CANTILEVER SLIDING GATES EXTRA LARGE SERIES

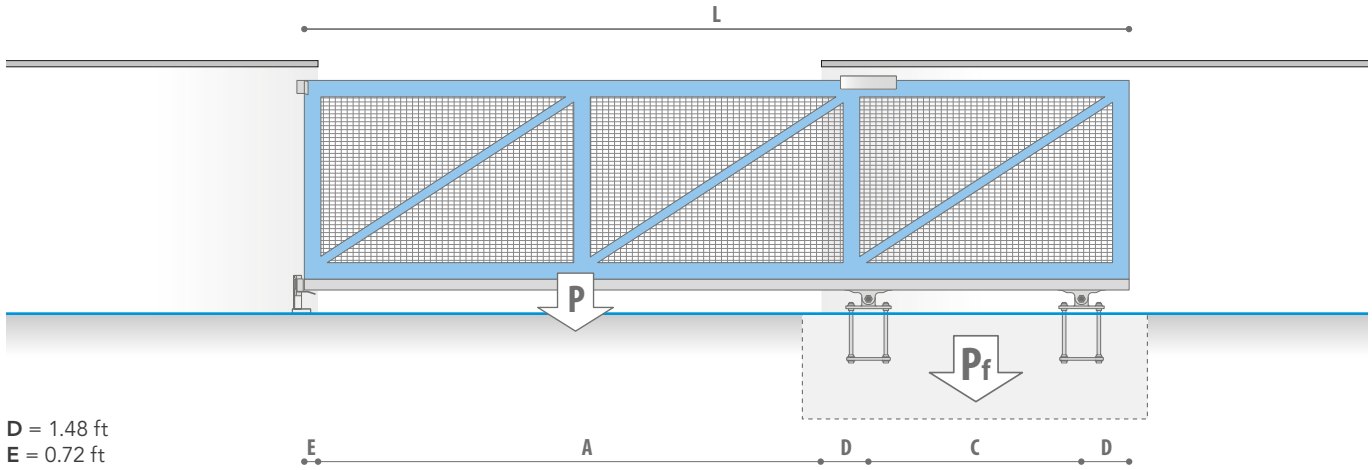

**D = 1.48 ft**  
**E = 0.72 ft**

XL	GATE WEIGHT ONLY																			
	800 lbs					1000 lbs					1200 lbs					1400 lbs				
A	C	L	PM	P	PF	C	L	PM	P	PF	C	L	PM	P	PF	C	L	PM	P	PF
20 ft	2.8	26.48	392	1452	9927	3.47	27.15	402	1760	9485	4.2	27.88	413	2086	9043	5	28.68	425	2433	8601
30 ft	4.72	38.4	569	1593	9599	5.75	39.43	584	1898	9157	6.87	40.55	601	2223	8715	8.12	41.8	619	2570	8273
40 ft	7.13	50.81	753	1769	9272	8.56	52.24	774	2080	8830	10.15	53.83	798	2412	8388	11.91	55.59	824	2769	7946
50 ft	10.08	63.76	945	1965	8944	11.98	65.66	973	2286	8502	14.09	67.77	1004	2631	8060	16.45	70.13	1039	3003	7618
60 ft	13.64	77.32	1146	2177	8617	16.08	79.76	1182	2511	8175	18.8	82.48	1222	2872	7733	21.84	85.52	1267	3263	7291
70 ft	17.87	91.55	1357	2403	8289	20.93	94.61	1402	2754	7847	24.36	98.04	1453	3134	7405	28.22	101.9	1510	3548	6963

## XL SUPPORT ROLLER

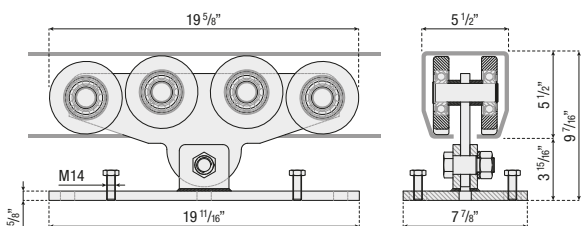

## XL TRACK

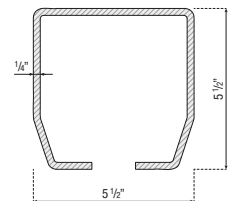

Barcode	L (ft)	TRACK WEIGHT	FINISHING
333.6	20	14.82 lb/ft	galvanized

## XL FOUNDATION PLATE

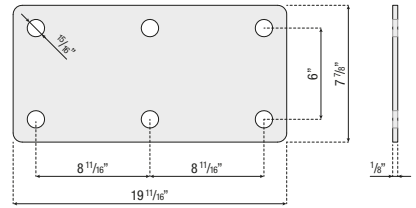

303.8XL	2

## XL GUIDE ROLLER

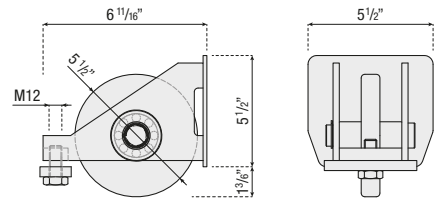
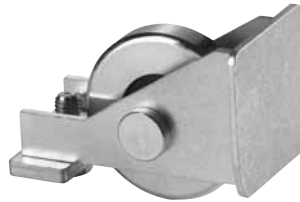

307.XL	2

## XL STEEL CAP

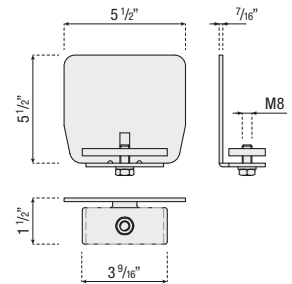

309.XL	4

## XL GATE CATCH

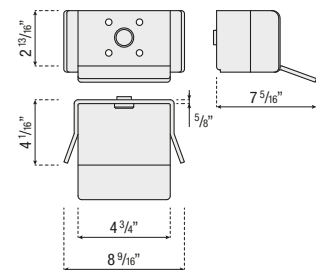

310.XL	2

# TOP CANTILEVER TRACK

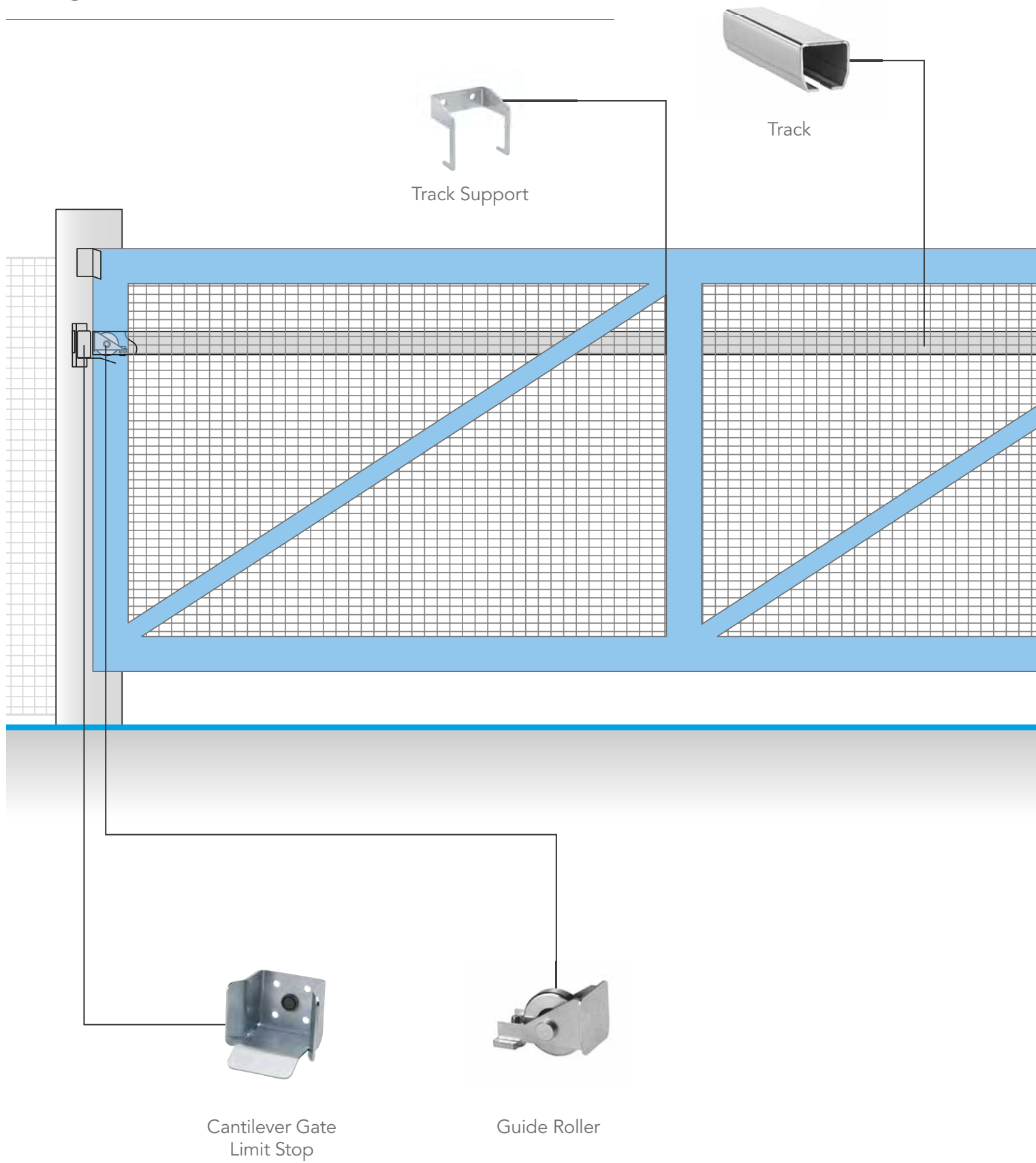

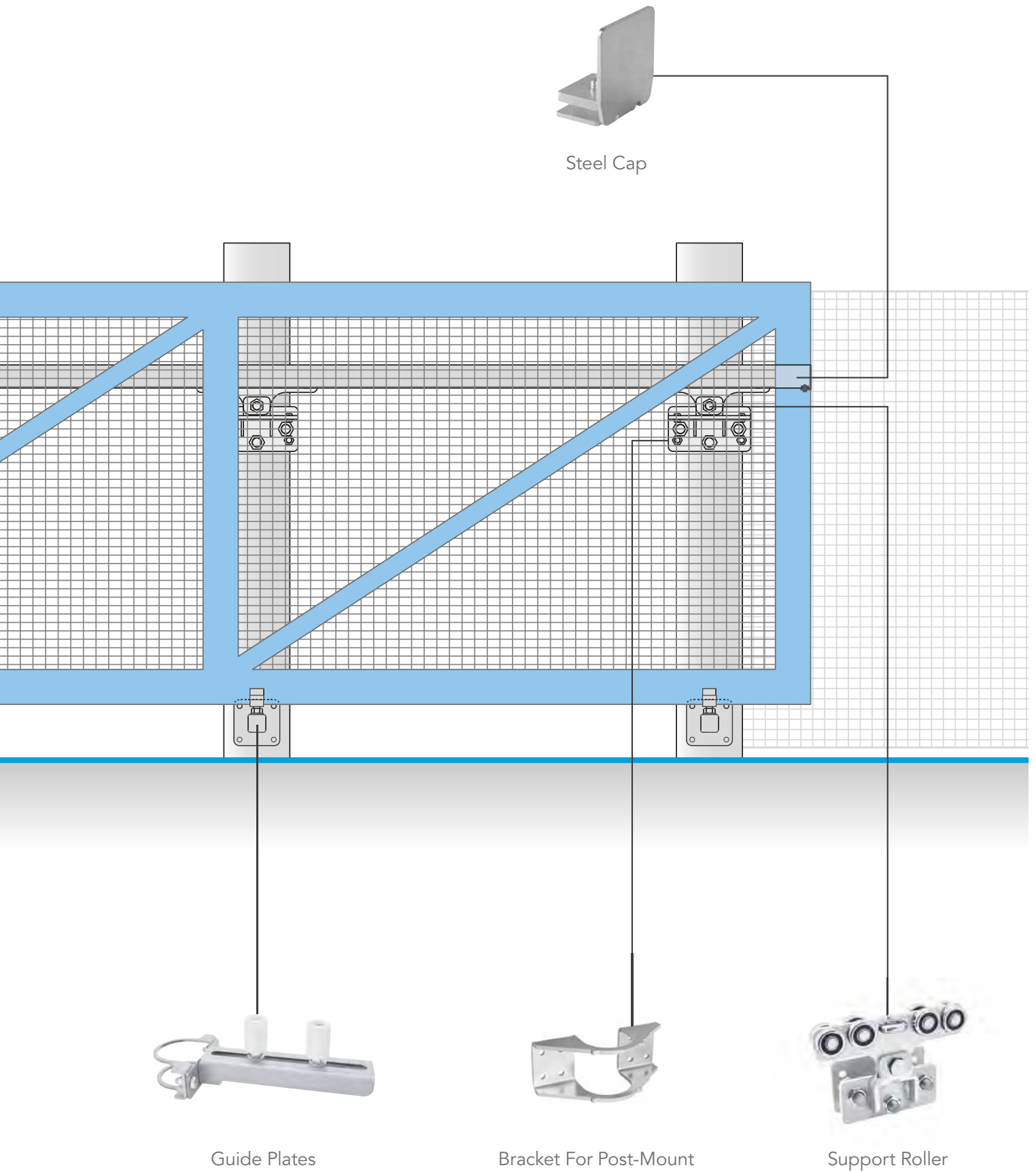

# TOP CANTILEVER TRACK ACCESSORIES

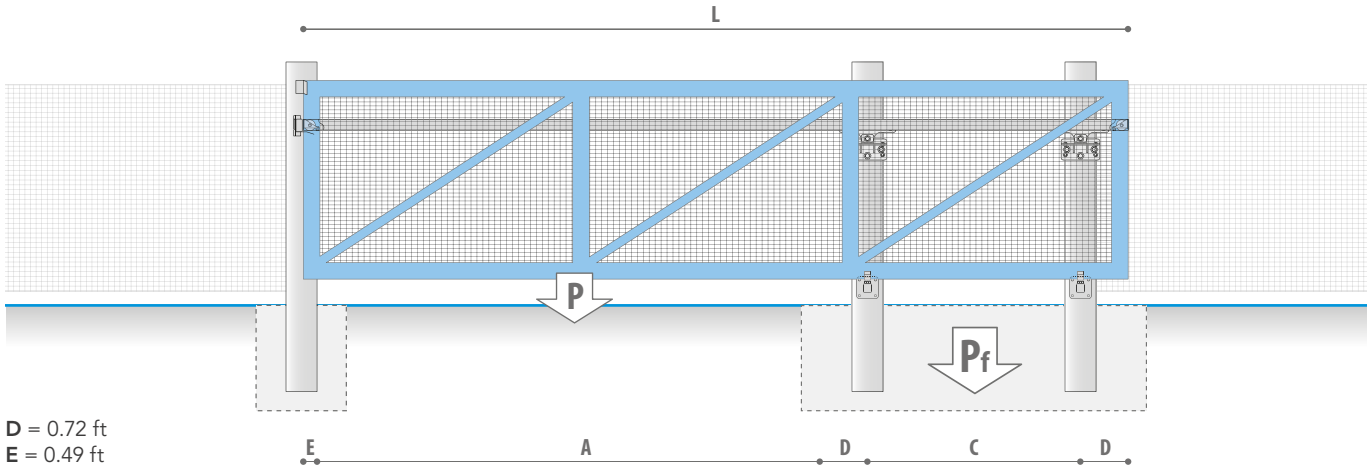

D = 0.72 ft  
E = 0.49 ft

M	GATE WEIGHT ONLY																			
	300 lbs					400 lbs					500 lbs					600 lbs				
A	C	L	PM	P	PF	C	L	PM	P	PF	C	L	PM	P	PF	C	L	PM	P	PF
12 ft	1.82	15.75	56	449	2793	2.55	16.48	58	608	2572	3.43	17.36	61	784	2351	4.48	18.41	65	985	2130
14 ft	2.15	18.08	64	451	2778	3	18.93	67	608	2557	4.01	19.94	70	783	2336	5.24	21.17	75	982	2115
16 ft	2.49	20.42	72	455	2762	3.46	21.39	76	610	2541	4.62	22.55	80	784	2320	6.03	23.96	85	983	2099
18 ft	2.84	22.77	80	460	2747	3.94	23.87	84	615	2526	5.25	25.18	89	788	2305	6.84	26.77	95	987	2084
20 ft	3.21	25.14	89	466	2731	4.44	26.37	93	621	2510	5.91	27.84	98	794	2289	7.68	29.61	105	993	2068
22 ft	3.6	27.53	97	473	2715	4.96	28.89	102	627	2494	6.58	30.51	108	801	2273	8.55	32.48	115	1001	2052
24 ft	4.01	29.94	106	480	2700	5.5	31.43	111	635	2479	7.28	33.21	117	809	2258	9.45	35.38	125	1009	2037

## M SUPPORT ROLLER

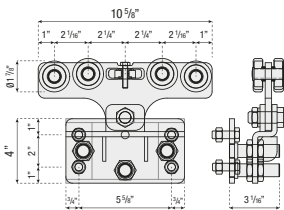

306.9MT 1

## M SUPPORT ROLLER BRACKETS FOR POST-MOUNT



	POST DIMENSION	
AU10771	Ø 3"	1
AU11201	Ø 4"	1
AU11241	[ ] 4" x 4"	1

## M TRACK SUPPORT

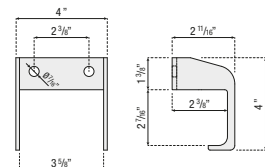

AU130621 10



## M TRACK

	L (ft)	TRACK WEIGHT	FINISHING
323.6	20	3.53 lb/ft	galvanized

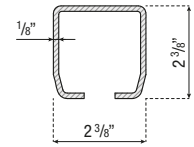

## GUIDE PLATES

	POST DIMENSION	
215.32.89	Ø 3 1/2"	2
215.32.102	Ø 4"	2
215.34.89	Ø 3 1/2"	2
215.34.102	Ø 4"	2

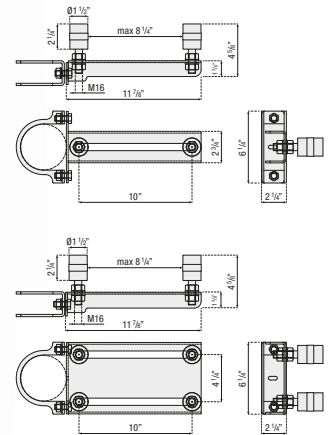
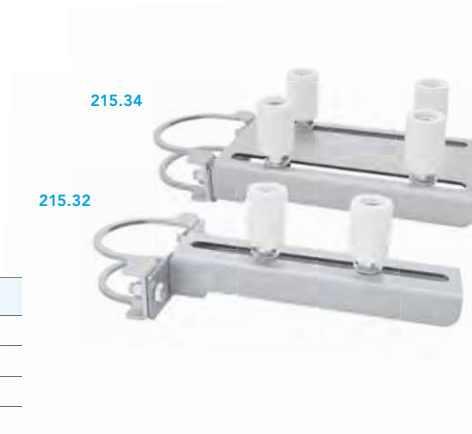

## M GUIDE ROLLER

307.M	2

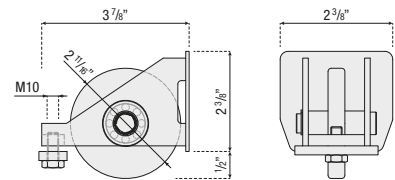

## M STEEL CAP

309.M	10

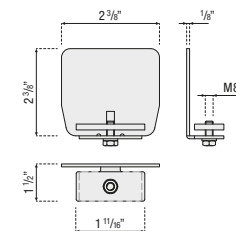

## M GATE CATCH

310.M	2

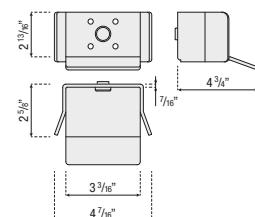

## CANTILEVER SLIDING GATES ACCESSORIES

### GUIDE PLATES TO BE FIXED WITH LONG HOLE

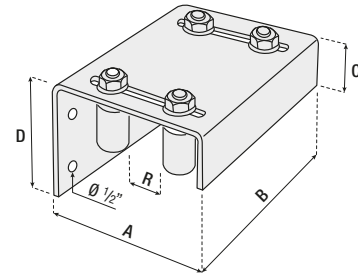
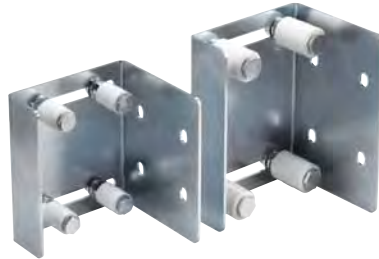

	A	B	C	D	R <sub>min-max</sub>	N° ROLLERS	
204.1	7 1/8"	7 7/8"	2 3/4"	6 1/4"	1 1/8" - 4"	4x Ø 1 1/8"	4
204.2	7 1/2"	9 7/8"	2 3/4"	6 1/4"	1 5/8" - 3 1/8"	4x Ø 1 5/8"	4

### ADJUSTABLE GUIDE PLATES TO BE FIXED

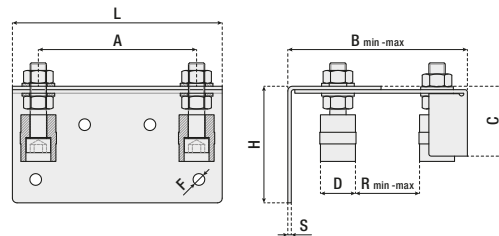

	R <sub>min-max</sub>	L	H	A	B <sub>min-max</sub>	C	D	F	S	
208.1	1 5/8" - 3 1/8"	7 1/8"	4"	5 3/8"	8 1/2" - 8 7/8"	2 3/8"	1 3/16"	3/8"	1/8"	2
208.22	3" - 4 1/2"	11"	4 3/8"	8 5/8"	8 1/8" - 10 3/8"	3 1/2"	1 5/8"	1/2"	3/16"	2

### GUIDE PLATE BRACKETS FOR POST-MOUNT



	POST DIMENSION	APPLICATION	
AU11231	Ø 3 1/2"	208.22	2
AU11221	Ø 4"	208.22	2
AU11041	[] 4" x 4"	208.22	2

## GUIDE PLATES

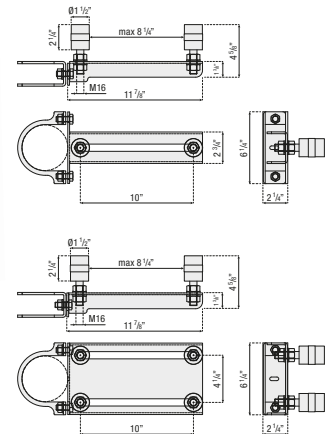

	POST DIMENSION	
215.32.89	$\emptyset\ 3\ \frac{1}{2}''$	2
215.32.102	$\emptyset\ 4''$	2
215.34.89	$\emptyset\ 3\ \frac{1}{2}''$	2
215.34.102	$\emptyset\ 4''$	2

## BRACKET GUIDE TO BE FIXED WITH TWO ROLLERS

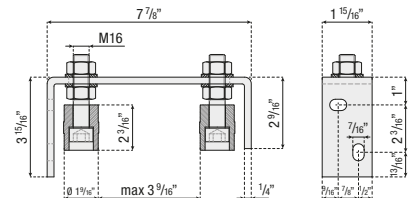

212.3	4

## BRACKET GUIDE TO BE FIXED

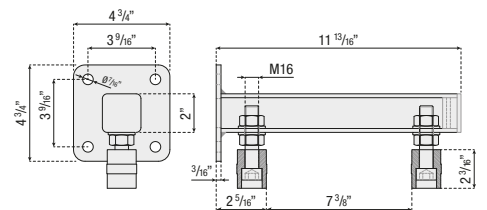

213.3B	2

## GUIDE ROLLERS

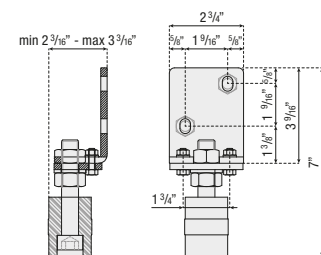

214.3B	2

# CANTILEVER SLIDING GATES ACCESSORIES

## WHITE NYLON GUIDE ROLLERS

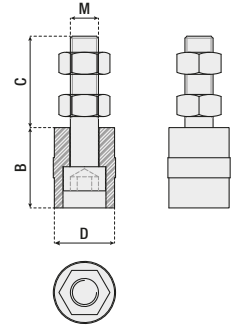

	D	B	C	M	
220.1	1"	1 5/8"	1 11/16"	M12	20
220.2	1 3/16"	1 5/8"	1 3/4"	M14	16
220.3	1 5/8"	2 1/4"	2"	M16	12
220.4	2"	1 7/8"	1 7/8"	M20	12

## NYLON ROLLER COVERS

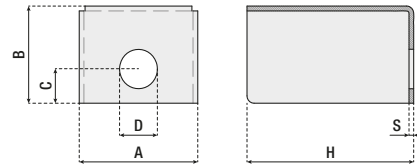
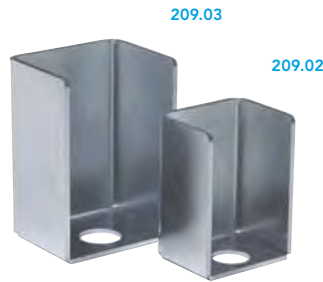

	H	A	B	C	D	S	APPLICATION	
209.03	2 1/4"	1 5/8"	1 1/4"	7/16"	1/2"	1/8"	220.2	12
209.02	2 3/4"	2"	1 1/2"	1/2"	5/8"	1/8"	220.3	12

## RUBBER NBR SH80 GUIDE ROLLERS

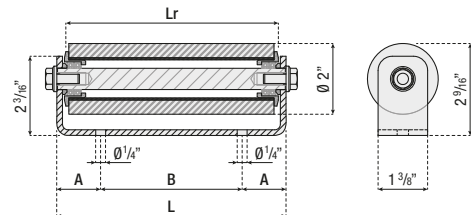

	D	LR	L	H	B	I	
225.03	2"	3"	3 7/16"	2 1/2"	1 3/8"	1 5/8"	8
225.06	2"	6"	6 3/8"	2 1/2"	1 3/8"	1 5/8"	4
225.12	2"	11 3/4"	12 1/4"	2 1/2"	1 3/8"	1 5/8"	8

# SLIDING GATES WHEELS

## PREMIUM 2" AND 4" WHEELS

with V groove

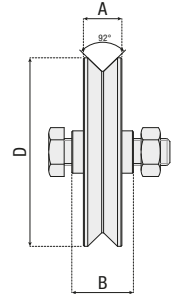

	D	A	B	CAPACITY	BEARINGS	BOLT	
100.50	2"	1 1/16"	1"	220 lb	1	M10x45	10
101.100	4"	3/16"	1 3/8"	1102 lb	2	M14x70	4

## BLACK STEEL BOX FOR 4" PREMIUM V GROOVE WHEELS

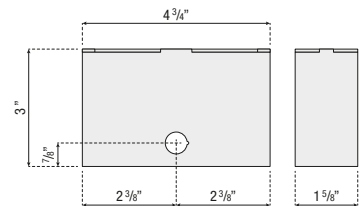

179.BOX.80	2

## 4" AND 6" WHEELS

with V groove and 2 bearings

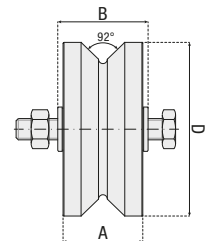

	D	A	B	CAPACITY	BOLT	FINISHING	
100.50	4"	1 3/4"	2"	2200 lb	UNC 1/2" x 3 1/4"	Galvanized Steel	1
101.100	6"	1 3/4"	2"	2800 lb	UNC 5/8" x 3 1/4"	Galvanized Steel	1

## TANDEM 4" WHEEL

with V groove and 2 bearings

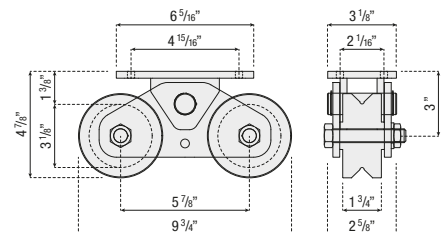

153.100.B	2

# INSTALLATION GUIDE

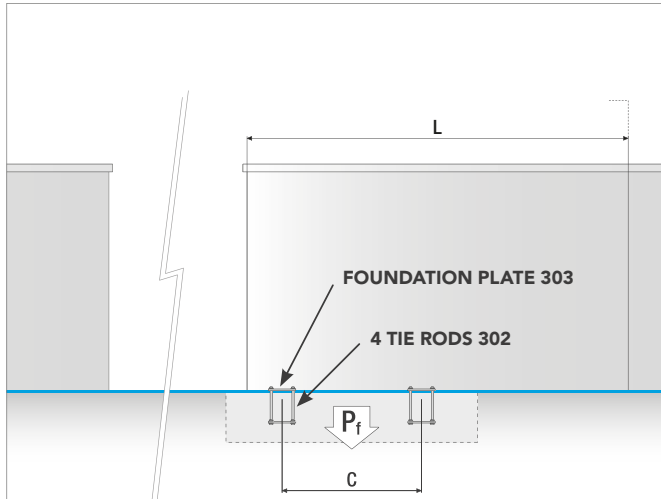

## 1. Foundations:

Information from the catalogue data sheet or the Hi Motions calculator system will verify distance between carriages "C" and overall gate length "L".

Be sure that the space available (with gate completely open) is enough to carry out the installation. Keep to the minimum foundation depth (Pf) and concrete weight as recommended by the data sheet or by Hi Motions calculator system. Please note that reinforced concrete weight is about 2.000Kg. per cubic meter.

Before the foundation base concrete sets, install the tie rods (302) using the carriage fixing plates (303). Remember to install the carriage plates the correct distance apart. Use a straight edge or plumb line to align the fixing plates (fig.A). The carriage fixing holes are oversized to allow for slight tie rod misalignment. It is very important that the carriages are installed on a level surface (fig.B). Further level adjustment can also be achieved by adjusting the tie rod nuts supplied with kit 302. The tie rods nuts have to be installed between the fixing plate (detail D) and the top of the carriages base

(detail C). Note that the best performance of the gate components is achieved by carrying out the above instructions. Both sets of carriage wheels should work together, simultaneously touching the track.

fig. A  
Plan view



fig. B

Side elevation

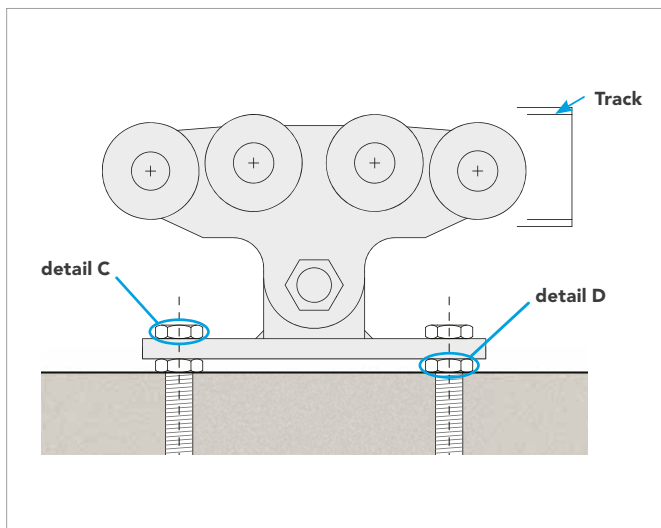

## 2. Positioning of the carriages:

Final positioning of the carriages must be carried out after the foundation base concrete has set. We would suggest that carriage alignment and levels are checked before tightening the upper nuts (detail C). If required further level adjustments can be made by adjusting the carriage plate fixing nuts (detail D).

**3. Guide plate (detail E): - from code 200.3 to code 212.0**

In case of heavy gates and when there aren't double support posts (internal and external to gate), we suggest to use two guide plates in order to guarantee the best safety conditions. After gate installation, we recommend to fix strongly all rollers on guide plates, locking very well bolts on plate (better if using specific locking glue). This operation must be done after check of rollers distance according gate width. Operation above guarantees best safety and reduce as well as possible any gate vibrations while sliding. We suggest rollers size according weight of the gate.

**4. Upper limit stop (detail F): - Part No 250.1 to 254.2**

For manual gates. Provides Guaranteed gate locking after closing. Ideal for wind effected gates and for enhanced security. A locking version is available (code 254.1/2) with a safety cylinder to lock the gate manually. Final fixing of upper limit stops should be checked when the gate is in the closed position.

**5. Lower gate limit stop (detail G):**

- Code 310 with adjustable support 311 (to be fixed) or 312 (to be welded)  
Make your choice according to the following suggestions.

- If you are using the ground support (311), it has to be installed on a concrete base, check the alignment with the gate. Fix limit stop (310) with bolts supplied. This support allows up and down adjustment only.
- If you are using welded support (312), pay attention to the height of meeting point before welding into place. This support allows left and right adjustment only.
- You can weld the limit stop bracket directly to a steel post without either of the above support brackets. Please note that there will be no vertical or horizontal adjustment.

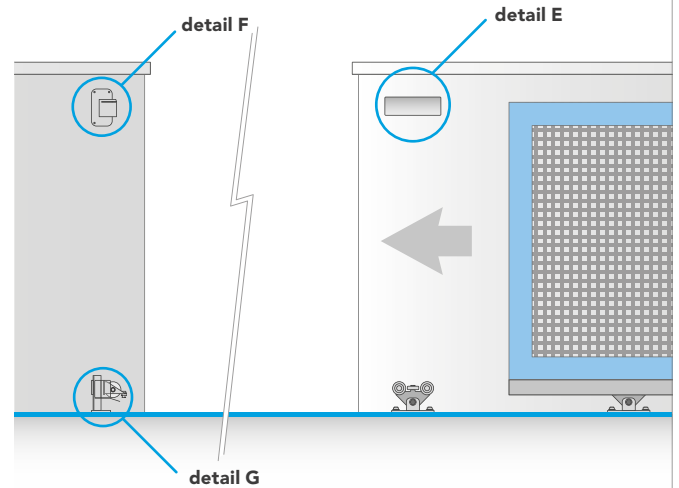

**6. Guide roller assembling (code 307)**

- Release screw on fixing plate (detail H) to allow guide roller assembly to slide into track.
- When the guide roller assembly is in position, lock into place using the M10 locking bolt.
- Cantilever gates require a guide roller assembly at both ends of the track. We would advise that heavy gates should not stay open for long periods without the use of any gate support. (310)

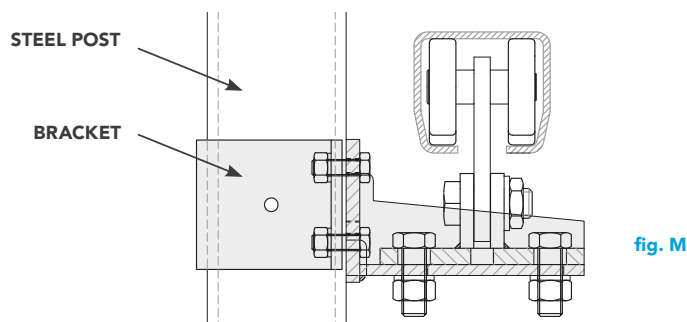
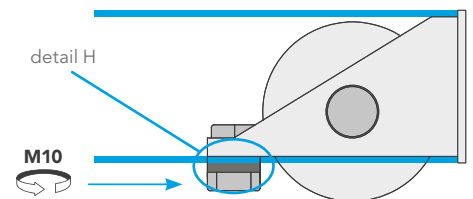

**Optional supports with brackets:**

Hi Motions Srl offer the exciting 304 'Easy Fit' cantilever carriage support system. The 'Easy Fit' cantilever support system consists of a pair of up to 4" square or 4" diameter post mounted brackets (fig.M).

**Notes (fig. M):**

- Easy Fit' square or circular bracket supports will enable you to install a cantilever gate in unusual ground conditions.
- Hi-Motions gives you the flexibility to install bracket supports on circular posts with dia. 3", 3½" and 4" or square posts of 3½" or 4".
- Support brackets can be locked into position using the 4 No M12 supplied with the kit.
- The square or circular posts have to be installed to the specified foundation details as recommended the Hi-Motions data sheets or calculator system.







# INDUSTRIAL DOORS OVERHEAD TRACKS

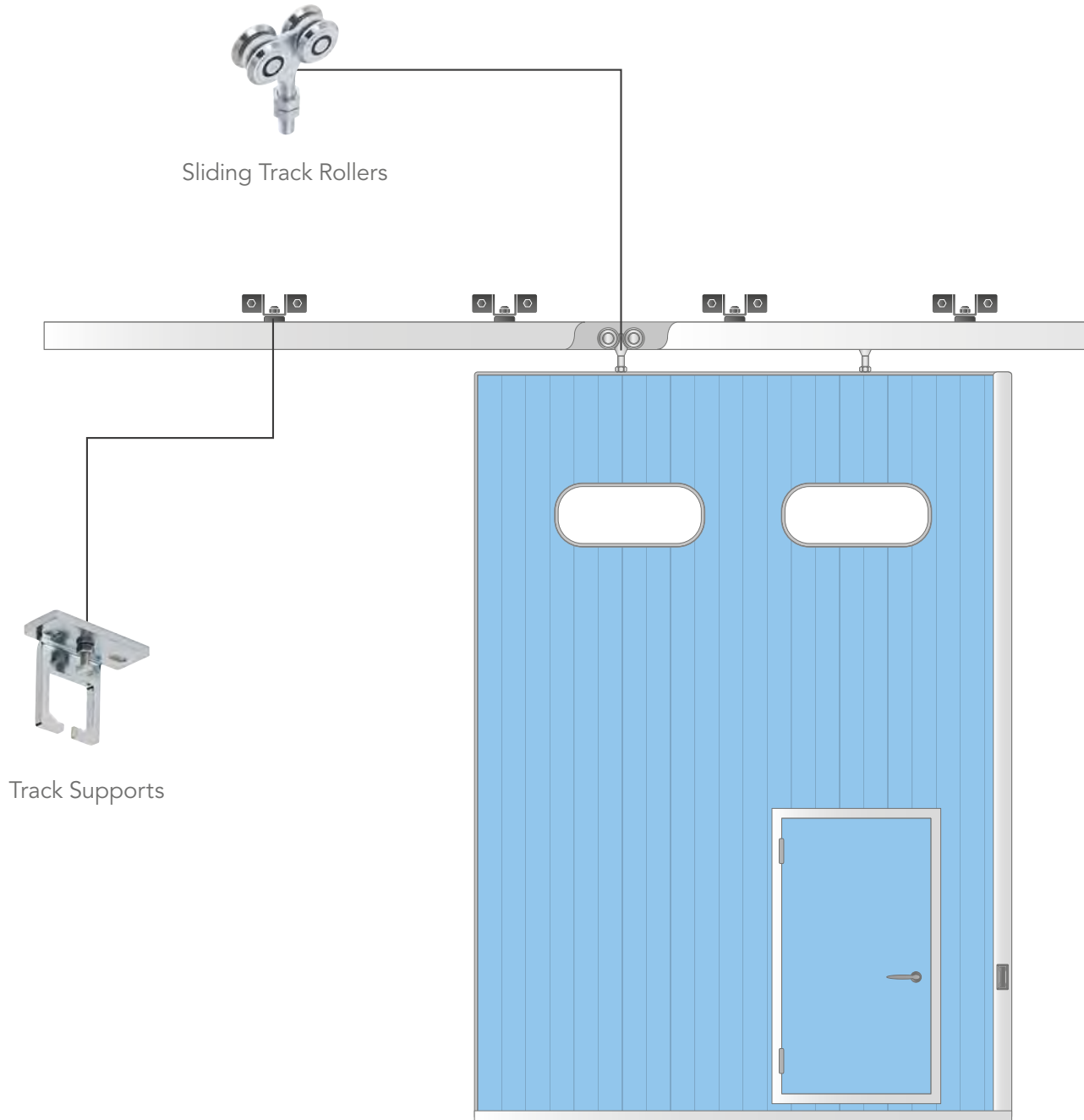

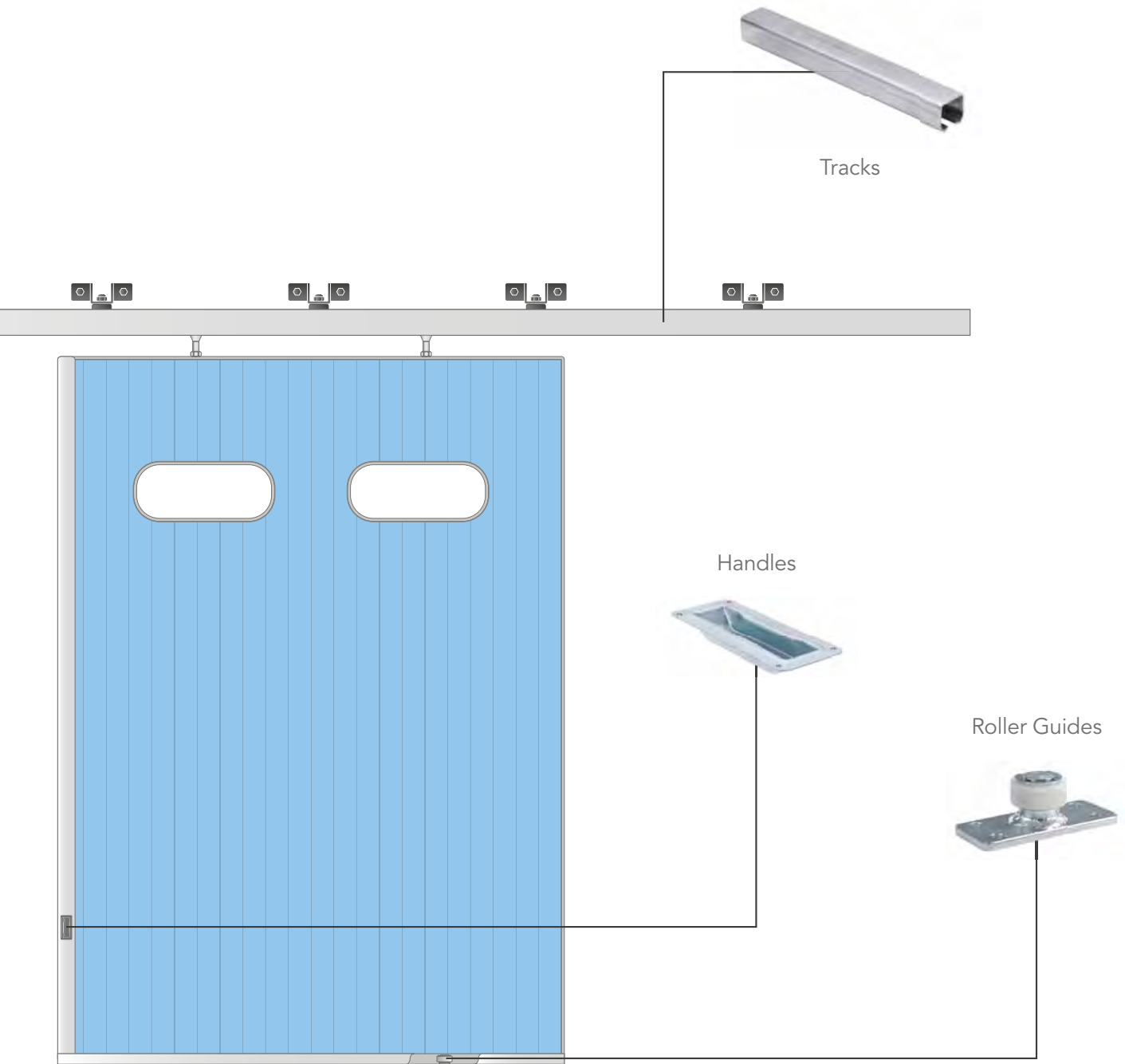

## INDUSTRIAL DOORS (OVERHEAD TRACKS)

### ROLLERS FOR PREMIUM TRACK

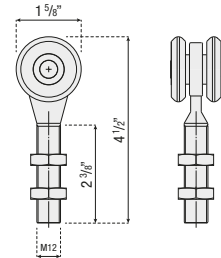

with bearings **2 wheels**

	CAPACITY	
603.42	450 lbs	12



### ROLLERS FOR PREMIUM TRACK

with bearings **4 wheels**

	CAPACITY	
604.42	675 lbs	8

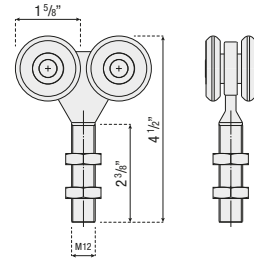

### PREMIUM GALVANIZED TRACK

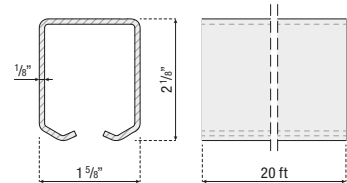

for 604.42 sliding roller

	L (ft)	LINEAR WEIGHT	WEIGHT
626.42	20	2 lb/ft	40 lbs



### SLIDING TRACK ROLLERS

with bearings **4 flat wheels**

	CAPACITY	
604.48P	790 lbs	8

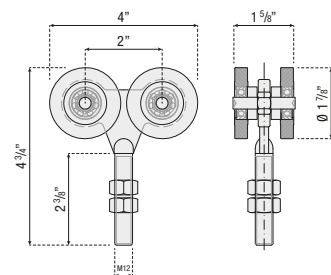

### GALVANIZED TRACK

for 604.48P sliding track roller

	L (ft)	LINEAR WEIGHT	WEIGHT
628.20	19	1.66 lb/ft	31.5 lbs

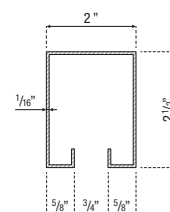

## TRACK SUPPORT

with ceiling mounting system

PREMIUM track version only

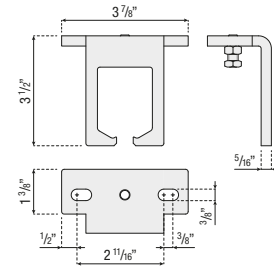

## JUNCTION FOR GALVANIZED TRACK

PREMIUM track version only

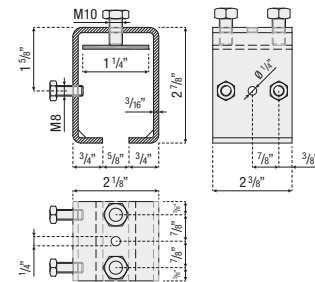

## END STOP CAP

PREMIUM track version only

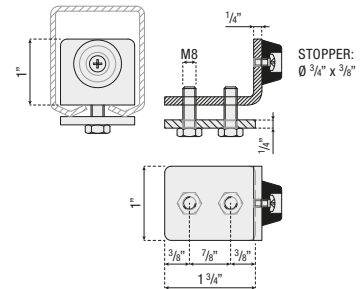
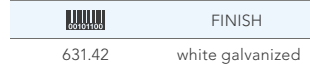

## UPPER NYLON ROLLER GUIDES WITH PLATE

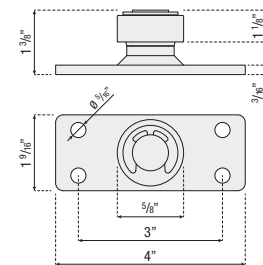

## EMBEDDED HANDLE

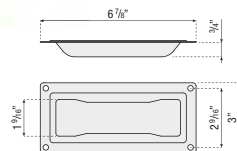

## HANDLE

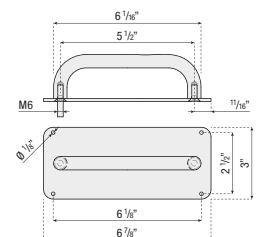







**HI-MOTIONS S.r.l. (HQ)**

Via dell'Industria, 91 - 36030 Sarcedo (VI) - ITALY

Tel. +39.0445.367536 - Fax +39.0445.367520

[www.himotions.com](http://www.himotions.com)

US branch :



6357 NW 99 AVE

Miami FL 33178

ph. + 305 - 418 0090

cell. + 305 - 716 0040

fax + 305 - 716 9271

email : [beninca.usa@beninca.com](mailto:beninca.usa@beninca.com)

[www.beninca-usa.com](http://www.beninca-usa.com)



**WE ARE.**  
**MADE IN ITALY**