



INSTRUCTIONS TO BIDDERS

1. BACKGROUND

- 1.1. The Town of Castor ("Town") is seeking bids for the supply and deliver two (2) NTI – LX-300 condensing boilers as outlined in the Request for Proposals. Drawings on Appendix "A"
- 1.2. Attributes of the project:
 - 1.2.1. Supply all labour
 - 1.2.2. Supply all materials
 - 1.2.3. Supply all equipment (dual high efficiency condensing boiler system)
 - 1.2.4. Supply all supervision and coordination
 - 1.2.5. Supply Glycol and flushing of entire system
 - 1.2.6. Integration with existing hydronic heating zones
 - 1.2.7. Electrical and control connections (coordination as required)
 - 1.2.8. Decommissioning of existing equipment
 - 1.2.9. Start up, Testing and balancing as required
 - 1.2.10. Commissioning upon project completion
- 1.3. The Town will receive bids until 1:00pm local time on June 30, 2026 ("Bid Closing").

2. SUBMISSION OF BIDS

- 2.1. Each Bid shall be addressed to the Town either in a signed, sealed envelope clearly marked with the Bidder's name, address and "Fire Hall Boiler Project" or emailed to donna@townofcastor.ca
The sealed envelope containing the Bid shall be delivered before the Bid Closing to Town of Castor:

Town of Castor
Box 479, 4901-50 Ave.
Castor, AB T0C 0X0
Attention: Donna Rowland
- 2.2. Each Bidder shall submit a complete Bid on the Bid Form which forms part of the Bid Documents with the blank spaces filled in.
- 2.3. Proposals will be considered by the Town based on several factors including, but not limited to, quality of services to be provided and experience of the service provider. The Town reserves the right to reject any and all proposals, even if it is the lowest proposal based on financial considerations, work related experience or other such means.
- 2.4. The Town shall not be obligated to accept Bids that are unsigned, incomplete, conditional, illegible, unbalanced, obscure, contain irregularities of any kind, or contain mathematical or calculation errors of any kind.
- 2.5. Bids shall not be withdrawn, modified or clarified after being delivered in accordance with the Bid Documents unless such withdrawal, modification or clarification is made in writing and actually received by Donna Rowland of the Town of Castor prior to the Bid Closing. Any withdrawal, modification or clarification of the Bid must be followed by a letter of confirmation signed and sealed in the same manner as the Bid and delivered to the address for the Town of



Castor in the Invitation to Bid within 48 hours of the Notice of the Withdrawal, Modification or Clarification.

3. THE ACCESS TO INFORMATION ACT

3.1. All documents submitted to the Town will be subject to the protection and disclosure provisions of Alberta's "Access to Information Act" which allows persons a right of access to records in the Town's custody or control. It also prohibits the Town from disclosing the Bidder's personal or business information where disclosure would be harmful to the Bidder's business interests or would be an unreasonable invasion of personal privacy as defined in sections 19. Bidders are encouraged to identify what portions of their submissions are confidential and what harm could reasonably be expected from its disclosure. However, the Town cannot assure Bidders that any portion of the Bidder's documents can be kept confidential under the "Access to Information Act".

4. BID DOCUMENTS

- 4.1. The documents for the Bid are:
- Invitation to Bid
 - Instructions to Bidder
 - Bid Form
 - Proof of Insurance and WCB

5. VARIATION IN BID DOCUMENTS AND NO IMPLIED OBLIGATIONS

- 5.1. The Bidder shall carefully examine the Bid Documents. Any errors, omissions, discrepancies, or clauses requiring clarification shall be reported in writing to the Town at least 3 calendar days prior to the Bid Closing. Where necessary the Town shall respond to reported errors, omissions, discrepancies, or clauses requiring clarification by way of Addenda.
- 5.2. Should a Bidder fail to report any such errors, omissions, discrepancies, or clauses requiring clarification at least 3 calendar days prior to the Bid Closing, the Town shall be the sole judge as to the intent of the Bid Documents.
- 5.3. No implied obligation of any kind by or on behalf of the Town shall arise from anything in the Bid Documents, and the express covenants and agreements contained in the Bid Documents and made by the Town, are and shall be the only covenants and agreements that apply.
- 5.4. Without limiting the generality of Article 5.3, the Bid Documents supersede all communications, negotiations, agreements, representations and warranties either written or oral relating to the subject matter of the Bid made prior to the Bid Closing, and no changes shall be made to the Bid Documents except by written Addenda.

6. ADDENDA



6.1. Any changes to the Bid shall be in writing in the form of Addenda. Any Addenda issued to the Bid shall form part of the Bid Documents, whether or not the receipt of same has been acknowledged by a Bidder, and the cost for the project therein shall be included in the Bid Sum. Verbal representations shall not be binding on the Town nor form part of the Bid Documents. Technical inquiries into the meaning or intent of the Bid Documents must be submitted in writing to the person identified in Article 2.1 of the Instructions to Bidders.

7. HOLD BACK

7.1. There will be a 10% hold back to the Successful Bidder that will be paid upon completion of a clean final inspection.

8. PROJECT COMPLETION

8.1. The Successful Bidder shall complete the project within the time specified in the receipt of the Letter of Intent from the Town.

9. PROJECT INSPECTIONS, INSURANCE AND WARRANTY

9.1. In addition to industry standard inspections, the Town reserves the right to hold regularly scheduled inspections throughout the duration of the project. The schedule of which will be outlined in the CCDC signed by the Successful Bidder.

9.2. The Bidder is fully responsible for obtaining all information required for the preparation of its Bid and for the execution of the Project. The Town is not responsible for undertaking any investigations to assist the Bidder. Bidders who obtain or rely upon such Non-Bid Information or other documents, do so entirely at their own risk.

9.3. It is the Bidder's obligation to obtain liability insurance for the project of no less than \$2,000,000.00 and to provide the Town with their WCB Number and all applicable licences and certificates.

9.4. The Bidder does warranty the project for a period of no less than six (6) months from the date of completion of the project, limited to: general character, suitability, seen or unseen deficiencies in the equipment, 3rd party inspection reports or any other item, deemed by the Town, to significantly impact the functionality of the equipment.

10. SUCCESSFUL BIDDER

10.1. Award of Contract by the Town occurs once the Bidder receives a Letter of Intent duly executed by the Chief Administrative Officer of the Town.

10.2. Following the receipt of the Letter of Intent, the Successful Bidder shall comply within the time required in Article 8.1.

10.3. Within 5 business days of receipt of the letter from the Town, the Successful Bidder shall duly execute the Contract and return the Contract to the Town.

10.4. Within 7 days of receipt of a Letter of Intent in accordance with Article 8.1, the Successful Bidder shall submit a proposed Schedule showing the anticipated time of commencement and completion of the project.

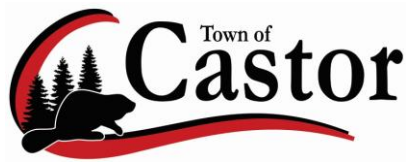

- 10.5. No equipment shall be seen to be purchased, agreed upon or delivered and no work can commence until the Contract has been executed by both parties thereto, and the liability insurance as required by the Contract has been accepted and filed with the Town.

11. BID EVALUATION CRITERIA

- 11.1. Bids will be evaluated based on a number of factors, including Bid price, reference checks, delivery time, Bidder's qualifications, Bidder's previous experience, Bidder's financial capability, equipment suitability as determined by the Town, specifications of the project in relation to the instructions.
- 11.2. The Town may, in its discretion, request clarification from a Bidder during the evaluation process. A request for clarification will not allow a Bidder to revise, amend or otherwise alter its Bid price.
- 11.3. In assessing a Bidder's qualifications, the Town will consider information regarding the experience of the Bidder, reference checks that may be conducted by the Town, and previous experience with the Bidder in doing similar projects.
- 11.4. In evaluating Bids, the Town expects to select the Bidder which will provide the overall best value to the Town, as determined by the Town in its sole discretion.
- 11.5. The Town does so disclose a local privilege clause in the evaluation of any Bid, whereby any local bidder shall receive privileged treatment and consideration up to five (5) percent of the grid.

12. BIDS EXCEEDING BUDGET

- 12.1. In addition to the rights contained within Article 12 herein, if the Bid Sum of every Bidder exceeds the amount the Town has budgeted for the Project, the Town may reject all Bids or attempt to negotiate a lower price with the Bidder who, in the sole and unfettered discretion of the Town, has submitted the most advantageous Bid.
- 12.2. Each Bidder acknowledges and agrees that the Town has the sole and unfettered discretion to employ any criteria in order to determine the Bid most advantageous to the Town, that the Town has no obligation to disclose such criteria nor employ the criteria listed outlined in Article 11 Bid Evaluation Criteria.
- 12.3. By submitting its Bid, each Bidder waives its right to contest in any action, application, case or legal proceeding in any court, the decision which the Town may pursue under Article 12.1 and 12.2 herein.

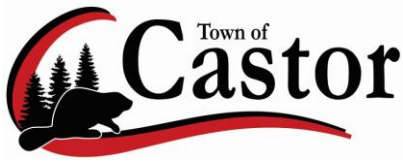

**BID FORM
TOWN OF CASTOR**

1.1 BID SUBMITTED TO

Town of Castor ("Town")
c/o Donna Rowland
Box 479, 4901-50 Ave.
Castor, AB T0C 0X0

Project: Fire Hall Boiler Replacement Project

1.2 BID PRICE

We, _____
(Company)
of _____
(Business Address)

having examined the Documents as issued by the Town, and having visited the site(s) of where the Work is required to be undertaken; hereby offer to enter a Contract to complete the project required by the Bid Documents for the sum as follows:

- | | |
|------------------------------|----------|
| 1. Sub-Total (excluding GST) | \$ _____ |
| 2. GST | \$ _____ |
| 3. Total | \$ _____ |

in Canadian funds, which price includes any specified cash and contingency allowances and the applicable taxes in force at this date and except as may be otherwise provided in the documents.

1.3 BIDDER'S INFORMATION

Legal Name: _____
Address: _____
Attention: _____
Phone: _____
Email: _____
Worker's Compensation Number: _____



1.4 BIDDER'S PREVIOUS EXPERIENCE

The Bid includes at least three descriptions of previous projects completed by the bidder within the past five years, which are similar in scope and magnitude to the scope of the project.

Previous Experience #1: Year Completed: _____

Description of the Project:

Project Location: _____

Owner: _____

Contact Information: _____

Previous Experience #2: Year Completed: _____

Description of the Project:

Project Location: _____

Owner: _____

Contact Information: _____

Previous Experience #3: Year Completed: _____

Description of the Project:

Project Location: _____

Owner: _____

Contact Information: _____

1.5 PROJECT DETAILS

The Bidder agrees to complete the following project and provide the following equipment in relation to the information provided in the invitation to bid and instructions:

1.6 BIDDER SECURITY

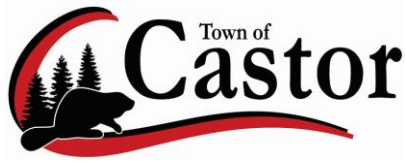

The Bidder security is attached to this Bid. The Bidder acknowledges and agrees that the Bidder security may be forfeited to the Town pursuant to the terms set forth in the Instructions to Bidders. The Bidder acknowledges that all statements and information contained in this Bid, to the best of its knowledge, are true and correct and hereby declares that:

- (a) it agrees to provide the equipment in compliance with the required completion schedule stated in the Agreement;
- (b) no person, firm, or corporation other than the undersigned has any interest in this project or in the proposed Agreement for which this Bidder is made;
- (c) it acknowledges and confirms that the Town has the right to accept any bid or to reject any or all bids in accordance with the Instructions to Bidders;
- (d) this Bid is open to acceptance for a period of thirty (30) days from the date of Bid Closing.

Signatures:

Signed, sealed, and submitted for and on behalf of:

Company: _____

(Name)

(Street Address or Postal Box Number)

(City, Province & Postal Code)

Signature: _____

Name & Title: _____

(Please Print or Type)

Dated at _____ this _____ day of _____, 2026



APPENDIX "A"

Mechanical Application

Job:	Firehall Boiler Upgrade
Contractor:	Town of Castor

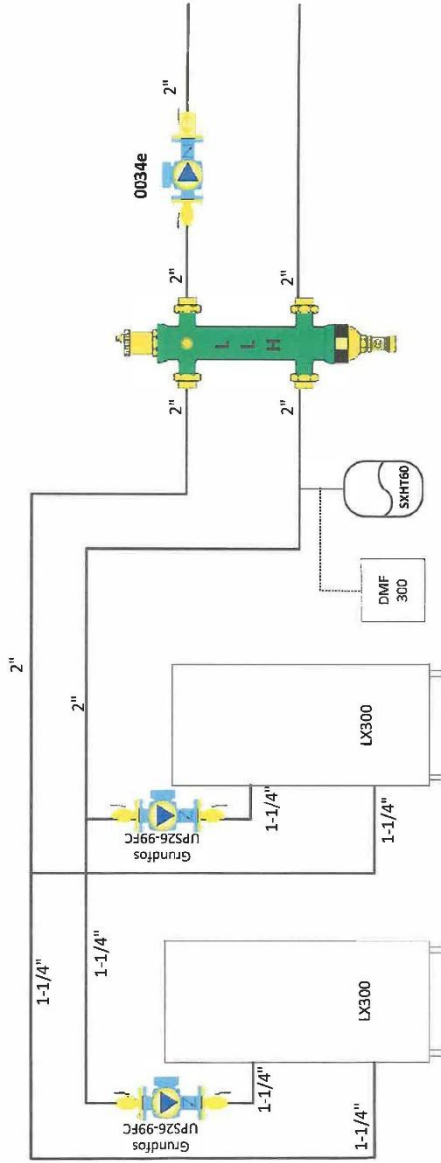

Mechanical Application

