

HI®

MOTIONS
OPENING SOLUTIONS

MADE IN ITALY



CATALOGO | CATALOGUE

STORIA HISTORY



B E N I N C À · H O L D I N G

HI
MOTIONS
OPENING SOLUTIONS

Il gruppo **BENINCA' HOLDING** in più di 30 anni ha fatto della specializzazione e della qualità il proprio punto di forza diventando in pochi anni uno dei principali player nel mercato internazionale dell'automazione.

HI MOTIONS è l'azienda del gruppo che porta con sé tutto il know how **BENINCÀ** con in più un forte orientamento al mercato e al cliente, principale interlocutore di tutte le scelte.

Opening solutions è il pay off che sintetizza la mission dell'azienda: offrire soluzioni per tutti i tipi di chiusure garantendo affidabilità, ma soprattutto flessibilità.

• • • • • • • •

In more than 30 years, the specialization and the quality have become the strong point of the **BENINCÀ HOLDING**: this group is now one of the biggest player in the international automation market.

HI MOTIONS is the company of the group with all the **BENINCÀ**'s know how with , in addition, a strong focus on the market and on the customer, which is the main figure in all its choices.

The company's pay off "opening solutions" says it all about its mission: offer solutions for all professional locking systems, with quality and, most of all, with flexibility.



MADE IN ITALY

HI MOTIONS da sempre considera la qualità e l'affidabilità del prodotto elementi essenziali per garantire il massimo servizio ai propri clienti. Per questo nel proprio processo produttivo ha fatto delle scelte precise in termini di qualità. Tutti i prodotti sono progettati e realizzati interamente in Italia, questo consente all'azienda di garantire al cliente un prodotto in grado di rispondere alle precise esigenze e richieste del mercato in termini di affidabilità e professionalità. Il made in Italy per HI MOTIONS dunque è non solo un elemento distintivo, ma una mission che perseguiamo ogni giorno anche attraverso il servizio offerto al cliente nella progettazione di servizi e sistemi personalizzati.

HI MOTIONS has always regarded product quality and reliability as essential elements in guaranteeing top-level service for its customers. For this reason, the company has implemented some specific adjustments to its production process in order to enhance quality. All the products are designed and manufactured entirely in Italy, therefore the company is able to guarantee customers a product capable of satisfying specific requirements and market requests in terms of reliability and professionalism. For HI MOTIONS, therefore, "made in Italy" quality is not only a distinctive element, but a mission we pursue day after day, also through the design of customised services and systems offered to customers.



PORTONI INDUSTRIALI INDUSTRIAL DOORS



CARRELLI
SCORREVOLI
SLIDING TRACK
ROLLERS



SUPPORTI
TRACK
SUPPORTS



MONOROTAIE
TRACKS

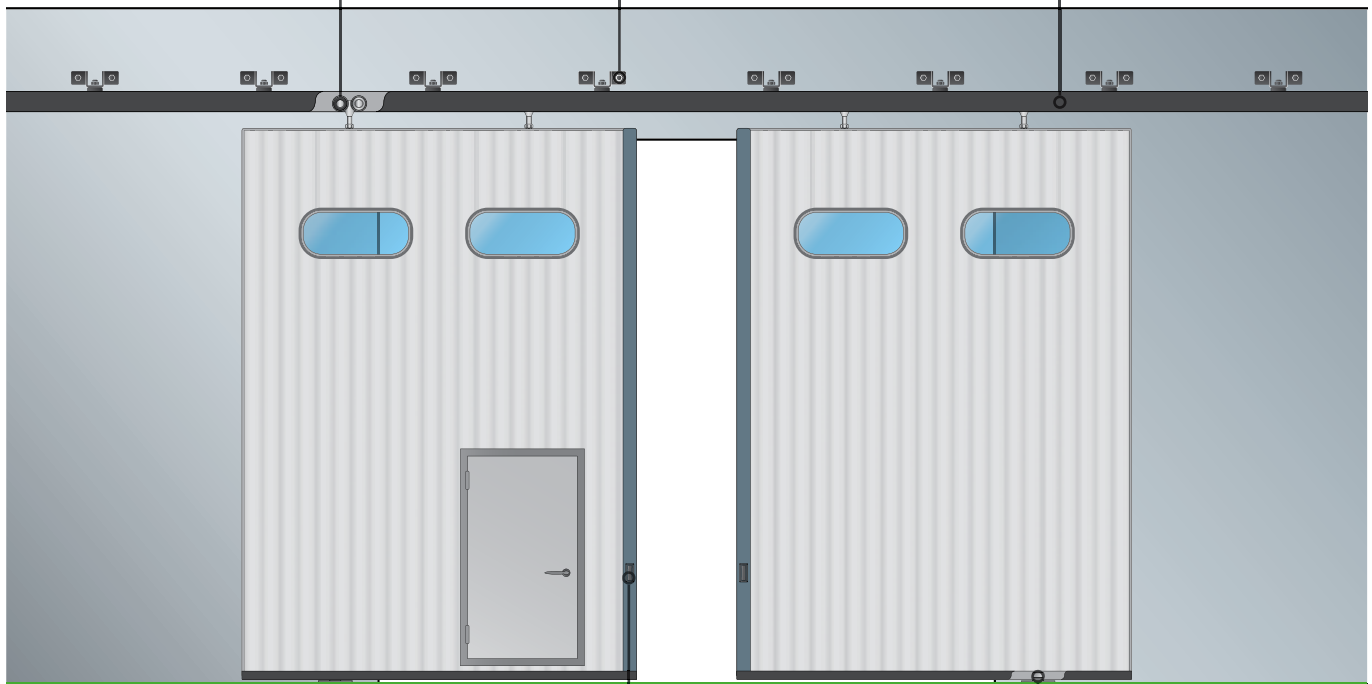

MANIGLIE
HANDLES



RULLI DI
GUIDA
ROLLER
GUIDES

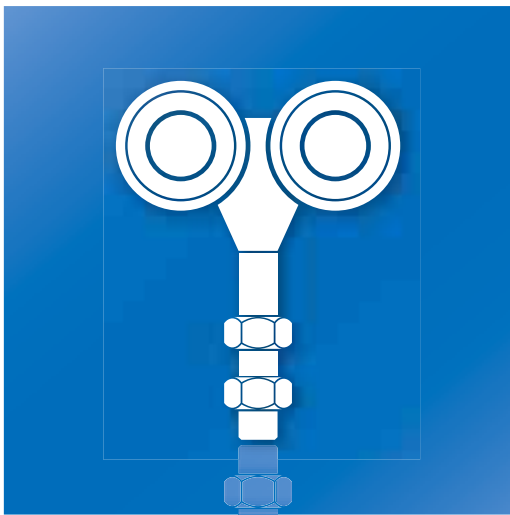

CARRELLI SCORREVOLI SLIDING TRACK ROLLERS

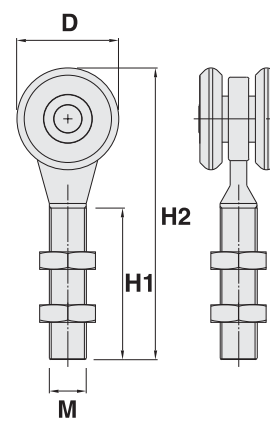

Carrelli scorrevoli per monorotaia - a bagno di sfere - 2 ruote
Sliding track rollers - with ball bearings - 2 wheels



	D (mm)	M (mm)	H1 (mm)	H2 (mm)	PORTATA CAPACITY	
601.24	24	M8	30	60	50 kg	20
601.42	42	M12	60	116	100 kg	12
601.55	55	M20	80	150	150 kg	8

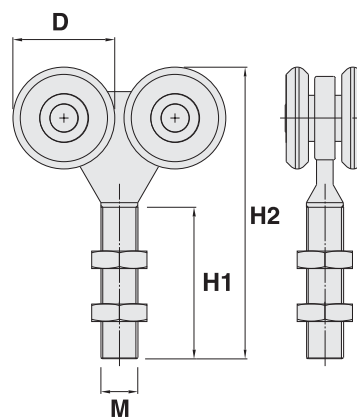

Carrelli scorrevoli per monorotaia - a bagno di sfere - 4 ruote
Sliding track rollers - with ball bearings - 4 wheels

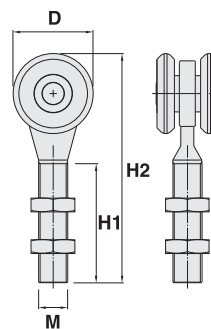

	D (mm)	M (mm)	H1 (mm)	H2 (mm)	PORTATA CAPACITY	
602.24	24	M8	30	60	75 kg	12
602.42	42	M12	60	116	200 kg	8
602.55	55	M20	80	150	250 kg	6

Carrelli scorrevoli per monorotaia - con cuscinetti - 2 ruote
Sliding track rollers - with bearings - 2 wheels





	D (mm)	M (mm)	H1 (mm)	H2 (mm)	PORTATA CAPACITY	
603.42	42	M12	60	116	200 kg	12
603.55	55	M20	80	130	400 kg	8

Carrelli scorrevoli per monorotaia - con cuscinetti - 4 ruote piane
Sliding track rollers - with bearings - 4 flat wheels



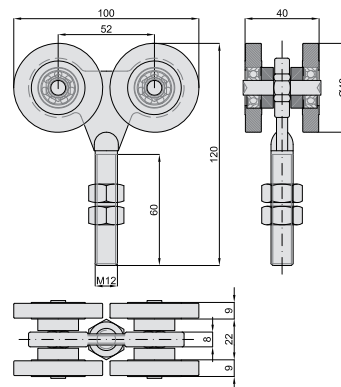

- per monorotaie serie 628
- for track range 628



	D (mm)	M (mm)	H1 (mm)	H2 (mm)	PORTATA CAPACITY	
604.48P	48	M12	60	120	350 kg	8

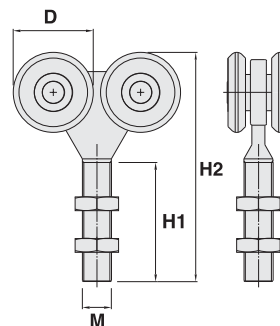

Carrelli scorrevoli per monorotaia - con cuscinetti - 4 ruote
Sliding track rollers - with bearings - 4 wheels

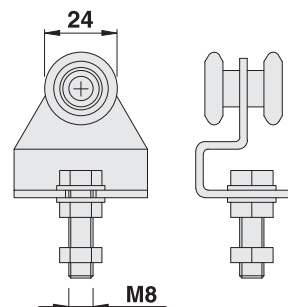

	D (mm)	M (mm)	H1 (mm)	H2 (mm)	PORTATA CAPACITY	
604.42	42	M12	60	116	300 kg	8
604.55	55	M20	80	130	600 kg	6

Carrelli scorrevoli per monorotaia - a bagno di sfere - 2 ruote
Sliding track rollers - with ball bearings - 2 wheels



	PORTATA CAPACITY	
605.24	30 kg	20

Carrelli scorrevoli per monorotaia - a bagno di sfere - 4 ruote
 Sliding track rollers - with ball bearings - 4 wheels

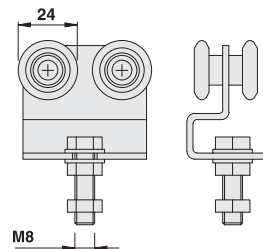

	PORTATA CAPACITY	
606.24	50 kg	20

Carrelli scorrevoli per monorotaia - a bagno di sfere - 4 ruote
 Sliding track rollers - with ball bearings - 4 wheels

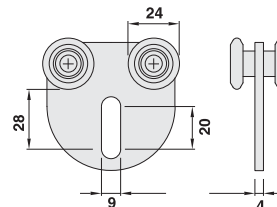

	PORTATA CAPACITY	
607.24	30 kg	20

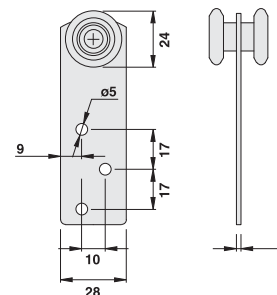

Carrelli scorrevoli per monorotaia - a bagno di sfere - 2 ruote
 Sliding track rollers - with ball bearings - 2 wheels

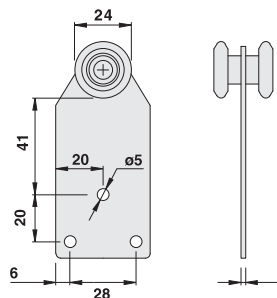

	PORTATA CAPACITY	
608.24	30 kg	20

Carrelli scorrevoli per monorotaia - a bagno di sfere - 2 ruote
 Sliding track rollers - with ball bearings - 2 wheels



	PORTATA CAPACITY	
609.24	30 kg	20

Carrelli scorrevoli per monorotaia - a bagno di sfere - 2 ruote
 Sliding track rollers - with ball bearings - 2 wheels

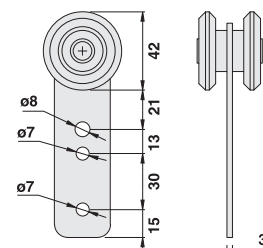



	PORTATA CAPACITY	
610.42	150 kg	12

MONOROTAIE TRACKS



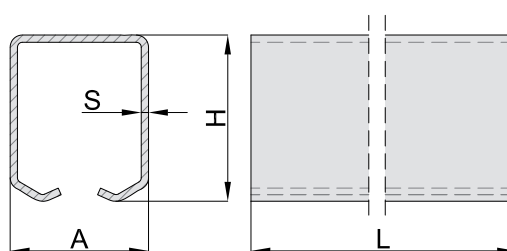

Monorotaia zincata per carrelli scorrevoli
Galvanized track for sliding rollers

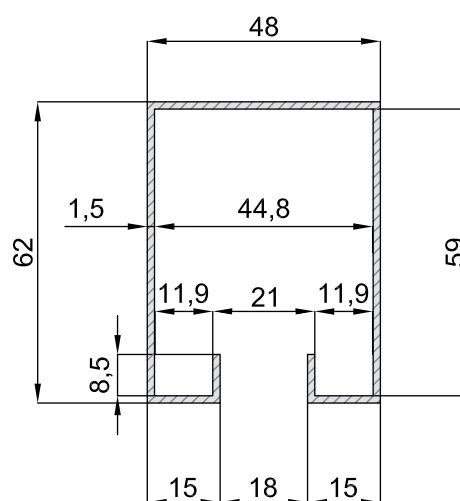

	A (mm)	H (mm)	S (mm)	L (mm)	Ø RUOTE CARRELLI Ø ROLLER WHEELS	PESO LINEARE LINEAR WEIGHT	PESO WEIGHT
623.24	33	31	2	3000	24	1,66 kg/m	5,05 kg
623.42	42	54	2,5	3000	42	2,98 kg/m	8,93 kg
623.55	57	67	3	3000	55	4,51 kg/m	13,52 kg
624.55	57	67	3	4500	55	4,51 kg/m	20,28 kg
626.24	33	31	2	6000	24	1,66 kg/m	10,10 kg
626.42	42	54	2,5	6000	42	2,98 kg/m	17,86 kg
626.55	57	67	3	6000	55	4,51 kg/m	27,04 kg

Monorotaia zincata 62x48 mm
Galvanized track 62x48 mm



	A (mm)	H (mm)	S (mm)	L (mm)	Ø RUOTE CARRELLI Ø ROLLER WHEELS	PESO LINEARE LINEAR WEIGHT	PESO WEIGHT
628.08	48	62	1,5	2432 (8ft)	48	2,48 kg/m	6,03 kg
628.10	48	62	1,5	3040 (10ft)	48	2,48 kg/m	7,54 kg
628.12	48	62	1,5	3648 (12ft)	48	2,48 kg/m	9,05 kg
628.20	48	62	1,5	5800 (19ft)	48	2,48 kg/m	14,38 kg

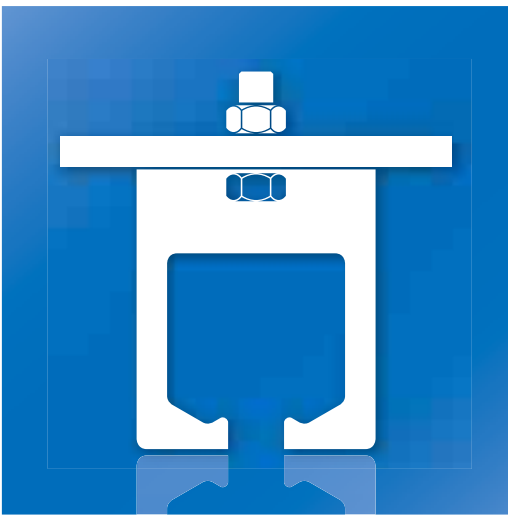

SUPPORTI TRACK SUPPORTS

Supporto a fissare per monorotaia con fissaggio a parete
Track support to be fixed with wall fixing system

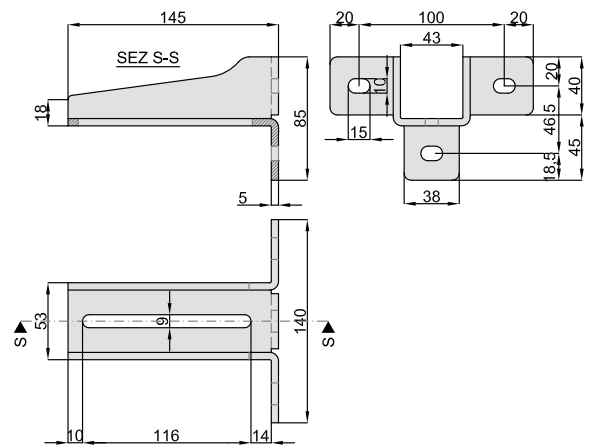

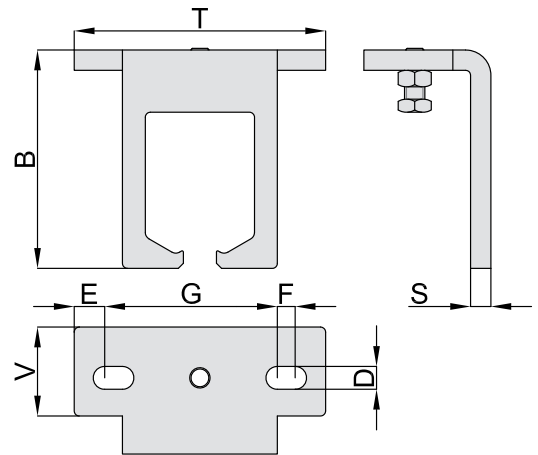

Supporto per monorotaia con fissaggio a soffitto
Track support with ceiling mounting system

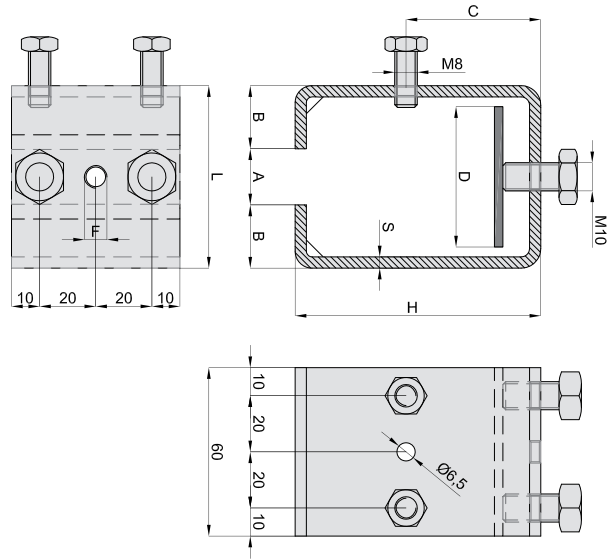

Barcode	B (mm)	T (mm)	S (mm)	D (mm)	E (mm)	F (mm)	G (mm)	V (mm)	Box Icon
631.24	61	77	6	7	10	7	52	30	10
631.42	88	99	8	9	12	9	68	35	10
631.55	105	118	8	9	12	9	87	35	10
631.48	100	100	8	9	10	9	68	35	10

Giunzione per monorotaia per carrelli scorrevoli
 Junction for sliding rollers tracks



	L (mm)	H (mm)	A (mm)	B (mm)	C (mm)	D (mm)	F (mm)	S (mm)	FINITURA FINISH
632.24	42	48	10,5	15,5	24	30	6,5	3	ZINCATO BIANCO / WHITE GALVANIZED
632.42	53,5	73	16,5	18,5	42	30	6,5	4	---
632.55	65	87,5	20	22,5	48	50	M8	4	---

Finecorsa interno per monorotaia per carrelli scorrevoli
 Internal limit for sliding rollers tracks

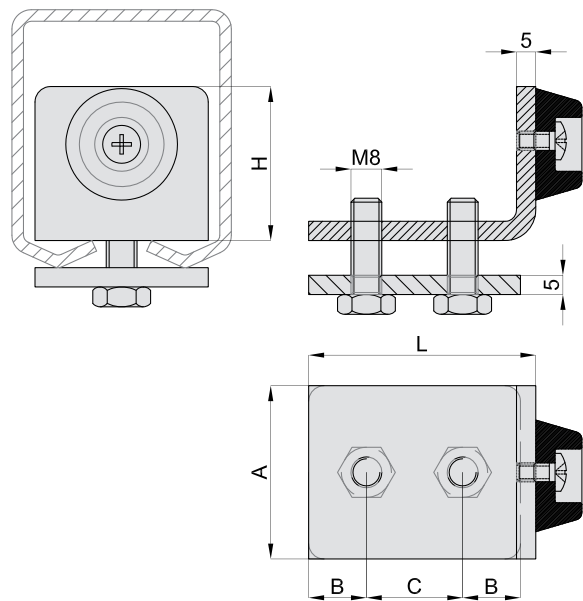



	L (mm)	H (mm)	A (mm)	B (mm)	C (mm)	TAMPONE STOPPER	FINITURA FINISH
633.42	45	25	25	10	20	D19 x 10 mm	ZINCATO BIANCO / WHITE GALVANIZED
633.55	59	40	45	15	25	D29 x 12 mm	---



RULLI DI GUIDA ROLLER GUIDES

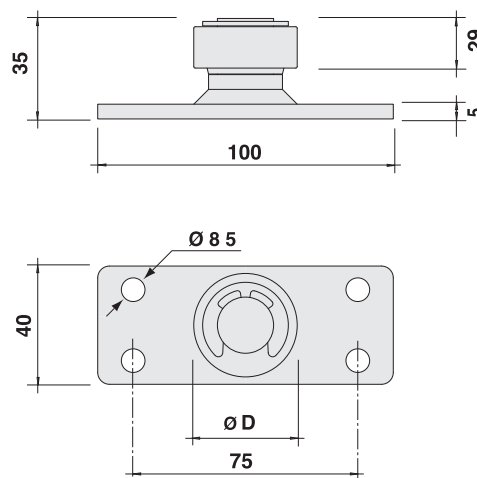

■ Rulli di guida superiore in nylon con piastrina
Upper nylon roller guides with plate

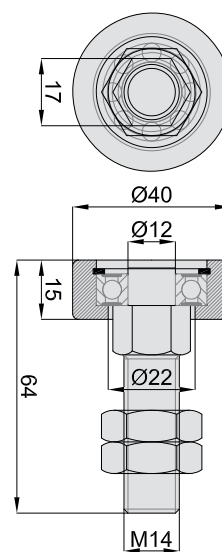

 00101100	Ø D (mm)	
641.35	35	12
641.42	42	12
641.52	52	12

■ Ruota di guida con perno
Guiding wheel with pin



 00101100	Ø D (mm)	
642.40	40	10

MANIGLIE HANDLES

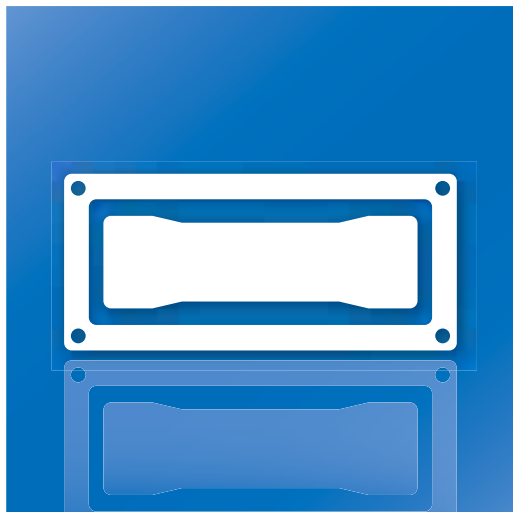

Maniglia ad incasso per portoni
Embedded pull handle

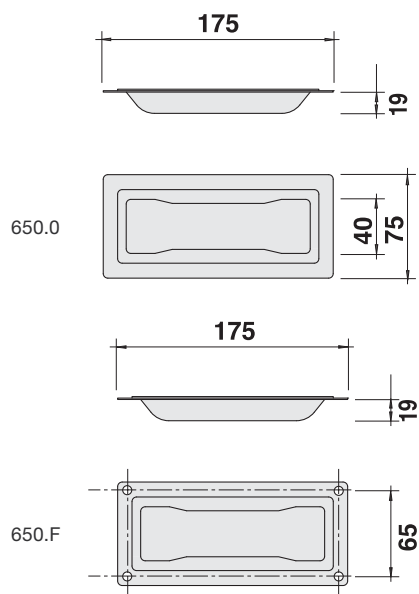

 00101100	
650.0	12
650.F	12

Maniglia per portoni
Handle for industrial gate

new

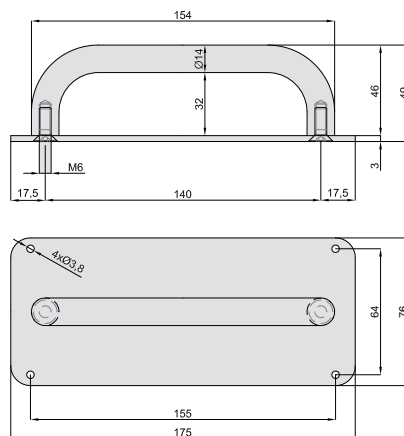

 00101100	
651.11	6



BENINCÀ · HOLDING

BENINCÀ HOLDING SpA

via Capitello, 43

36066 Sandrigo (VI) ITALY

T +39 0444 751030

F +39 0444 759728

www.benincaholding.com

US branch :

BENJOY AMERICA LLC. dba



6357 NW 99 AVE

Miami FL 33178

ph. + 1 - 305 - 418 0090

fax + 1 - 305 - 716 9271

beninca.usa@beninca.com

www.beninca-usa.com

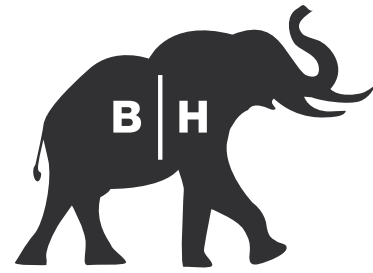

BENINCÀ HOLDING oggi è diventata una splendida realtà, un sogno che si è concretizzato per dare forma ad obiettivi di specializzazione da sempre perseguiti.

Una scelta istituzionale per esprimere una mission precisa: offrire soluzioni operando da specialisti nel settore automazione.

L'elefante è il testimone formale che abbiamo scelto per **BENINCÀ HOLDING**, il simbolo che meglio rappresenta la scelta precisa di solidità, affidabilità istituzionale, ma anche intelligenza e dinamismo verso i partners internazionali e verso tutti i clienti.

Today **BENINCÀ HOLDING** has become a splendid reality, a dream that has come true to give shape to aims of specialisation that we have always pursued.

A corporate decision to express a precise mission: offering solutions by acting as specialists in the automation sector.

The elephant is the symbol we have chosen for **BENINCÀ HOLDING**, the image that best represents our precise choice of corporate strength and reliability, but also intelligence and dynamism when interacting with international partners and with all customers.



AUTOMATISMI BENINCÀ SpA

via Capitello, 45

36066 Sandrigo (VI) ITALY

T +39 0444 751030

F +39 0444 759728

www.beninca.com

sales@beninca.it



AUTOMATISMI CAB Srl

via della Tecnica, 10 (Z.I.)

36010 Velo D'Astico (VI) ITALY

T +39 0445 741215

F +39 0445 742094

www.automatismicab.com

info@automatismicab.com



HI MOTIONS Srl

via dell'Industria, 91

36030 Sarcedo (VI) ITALY

T +39 0445 367536

F +39 0445 367520

www.himotions.com

info@himotions.com



RISE Srl

via Maso, 27

36035 Marano V. (VI) ITALY

T +39 0444 751401

www.riseweb.it

info@riseweb.it



BYOU

via Capitello, 45

36066 Sandrigo (VI) ITALY

T +39 0444 1510294

F +39 0444 759728

www.byouweb.com

info@byouweb.com



MYONE Srl

via T. Edison, 11

30035 Ballò di Mirano (VE) ITALY

T +39 041 412542

F +39 041 412542

www.myoneautomation.com

info@myoneautomation.com



HI-MOTIONS S.r.l.

Via dell'Industria, 91 // 36030 Sarcedo (VI) ITALY
T +39 0445 367536 // **F** +39 0445 367520
info@himotions.com // www.himotions.com