

# HYDRA-PAK Model 1500X

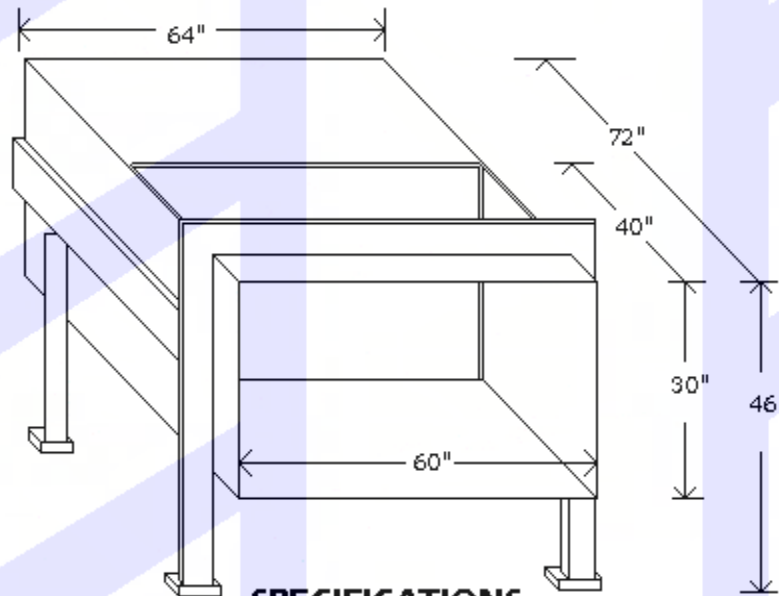

## SPECIFICATIONS

### MECHANICAL

Compactor Weight:	Gross 4100 lbs.
Charging Chamber Cap:	1.5 Cu. Yds.
Chamber Opening:	40" x 60" x 30"
Ram Face Diameter:	60" x 24"
Ram Penetration:	11 inches

### CONSTRUCTION

Sides	5/16", floor 3/8"
Hot Rolled Steel	
Reinforced	3" x 6" x 5/16"

### ELECTRICAL

Control System:	110 volts, 60 cycles
Motor:	10HP 3 Phase 60 Cycles, Power Range - 208-416-230-460-575 volts
Control Panel:	Fully wired with fuse protection, on-off switch, start-stop button, on indicator light, full indicator light, safety reset.

### HYDRAULICS

Compaction Force:	50,200 lbs. maximum
Compaction Force:	44,000 lbs. normal
Max. Displacement:	120 Cu. Yd. per Hour
Cycle Time:	40 seconds
Pressure:	
Normal:	1,750 psi
Maximum:	2,000 psi
Pump Capacity:	10 G.P.M.
Cylinder:	2 x 4" bore, 39 3/4" stroke
Ram Pressure:	30 psi
Oil Capacity:	20 gallons

**Specifications are approximate and subject to change without notification.  
Dimensions will vary with options in Compactor and Container size.**

HYDRA-PAK SYSTEMS LIMITED  
2501 Beryl Road  
Oakville, Ontario, L6J 7X3  
Tel: 905-844-7844  
email: [look@hydrapaksystems.com](mailto:look@hydrapaksystems.com)